

OWNERS MANUAL

CM-1031T

COMMERCIAL MICROWAVE OVEN

Bonn

COMMERCIAL MICROWAVE OVEN

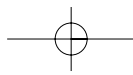

PRECAUTIONS TO AVOID POSSIBLE EXPOSURE TO EXCESSIVE MICROWAVE ENERGY

- (a) Do not attempt to operate this oven with the door open** since open-door operation can result in harmful exposure to microwave energy. It is important not to defeat or tamper with the safety interlocks.
- (b) Do not place any object** between the oven front face and the door or allow soil or cleaner residue to accumulate on sealing surfaces.
- (c) Warning:** If the door or door seals are damaged, the oven must not be operated until it has been repaired by a competent person; (1) door (bent), (2) hinges and latches(broken or loosened), (3) door seals and sealing surfaces.
- (d) Warning:** It is hazardous for anyone other than a competent person to carry out any service or repair operation that involves the removal of a cover which gives protection against exposure to microwave energy:
- (e) Warning:** Liquids or other foods must not be heated in sealed containers since they are liable to explode:
- (f) Warning:** Microwave heating of beverages can result in delayed eruptive boiling, therefore care must be taken when handling the container;
- (g) Warning:** The contents of feeding bottles and baby food jars must be stirred or shaken and the temperature checked before consumption, in order to avoid burns;

TABLE OF CONTENTS

<ul style="list-style-type: none"> • PRECAUTIONS TO AVOID POSSIBLE EXPOSURE TO EXCESSIVE MICROWAVE ENERGY1 • EARTHING INSTRUCTIONS2 • INSTALLATION2 • SPECIFICATIONS3 • IMPORTANT3 • IMPORTANT SAFETY INSTRUCTIONS4 • FEATURES DIAGRAM5 • FEATURES DIAGRAM (continued)6 • OPERATION PROCEDURE7 • CONTROLS8 TIME DEFROSTING8 COOKING IN ONE STAGE9 MEMORY FUNCTION10 +30 SEC11 CHECK FUNCTION11 DOUBLE QUANTITY FUNCTION11 CHILD SAFETY LOCK12 POWER SAVE MODE12 MUTE FUNCTION12 TO STOP THE OVEN WHILE THE OVEN IS OPERATING12 • COOKING INSTRUCTIONS13 • COOKING UTENSILS13 	<ul style="list-style-type: none"> • MICROWAVING PRINCIPLES14 • HOW MICROWAVES COOK FOOD14 • CONVERSION CHARTS14 • COOKING TECHNIQUES15 • DEFROSTING GUIDE16 • DEFROSTING CHART17 • COOKING CHART18 • REHEATING CHART19 • CARE OF YOUR MICROWAVE OVEN21 • CARE AND CLEANING21 • USE YOUR MICROWAVE OVEN SAFELY22 • BEFORE YOU CALL FOR SERVICE23 • QUESTIONS AND ANSWERS23 • QUESTIONS AND ANSWERS (continued)24 • WARRANT Y25 • TERMS AND CONDITIONS25 • TERMS AND CONDITIONS (CONTINUED)26 • CONTACT27
----------------------------------------------------------------------------------------------------------------------------------------------------------------------------------------------------------------------------------------------------------------------------------------------------------------------------------------------------------------------------------------------------------------------------------------------------------------------------------------------------------------------------------------------------------------------------------------------------------------------------------------------------------------------------------------------------------------------------------------------------------------------------------------------------------------------------------------------------------------------------------------------------------------------------------------------------------------------	----------------------------------------------------------------------------------------------------------------------------------------------------------------------------------------------------------------------------------------------------------------------------------------------------------------------------------------------------------------------------------------------------------------------------------------------------------------------------------------------------------------------------------------------------------------------------------------------------------------------------------------------------------------------------------------------------------------------------------------------------------------------------------------------

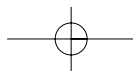

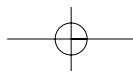

EARTHING INSTRUCTIONS

This appliance must be earthed. In the event of an electrical short circuit, earthing reduces the risk of electric shock by providing an escape wire for the electric current. This appliance is equipped with a cord having a earthing wire with a earthing plug. The plug must be plugged into an outlet that is properly installed and earthed.

WARNING : Improper use of the earthing plug can result in a risk of electric shock. Consult a qualified electrician or serviceman if the earthing instructions are not completely understood, or if doubt exists as to whether the appliance is properly earthed. If it is necessary to use an extension cord, use only a 3-wire extension cord that has a 3-blade earthing plug, and a 3-slot receptacle that will accept the plug on the appliance. The marked rating of the extension cord should be equal to or greater than the electrical rating of the appliance.

INSTALLATION

1 Steady, flat location

This oven should be set on a steady, flat surface. This oven is designed for counter top use only.

2 Leave space behind and side

All air vents should be kept clear. If all vents are covered during operation, the oven may overheat and, eventually, oven failure.

3 Away from radio and TV sets

Poor television reception and radio interference may result if the oven is located close to a TV, Radio antenna, feeder and so on. Position the oven as far from them as possible.

4 Away from heating appliance and water taps

Keep the oven away from hot air, steam or splash when choosing a place to position it, or the insulation might be adversely affected and breakdowns occur.

5 Power supply

- Check your local power source. This oven requires a current of approximately 6 amperes, 240V 50Hz.
- Power supply cord is about 0.6 meters long.
- The voltage used must be the same as specified on this oven. Using a higher voltage may result in a fire or other accident causing oven damage. Using low voltage will cause slow cooking. We are not responsible for damage resulting from use of this oven with a voltage of ampere fuse other than those specified.
- If the supply cord is damaged, it must be replaced by the manufacturer or its service agent or a similarly qualified person in order to avoid a hazard.

6 Examine the oven after unpacking for any damage such as:

A misaligned door, Broken door, A dent in cavity. If any of the above are visible, DO NOT INSTALL, and notify dealer immediately.

7 Do not operate the oven if it is colder than room temperature.

(This may occur during delivery in cold weather.) Allow the oven to become room temperature before operating.

8 The minimum height of free space necessary above the top surface of the oven is 100mm.

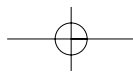

SPECIFICATIONS

POWER SUPPLY		240V AC 50Hz SINGLE PHASE WITH EARTHING
MICROWAVE	POWER CONSUMPTION	1350W
	OUTPUT POWER	1000W
	FREQUENCY	2450 MHZ
OUTSIDE DIMENSIONS (W x H x D)		560 x 344 x 483 mm (22.0 x 13.5 x 19.0 in.)
CAVITY DIMENSIONS (W x H x D)		369 x 221 x 400 mm (14.5 x 8.7 x 15.7 in.)
NET WEIGHT		APPROX. 17.5Kg (38.6 lbs.)
TIMER		20 min. 00 sec. (FULL POWER)
POWER SELECTIONS		4 LEVELS

* Specifications are subject to change without notice.

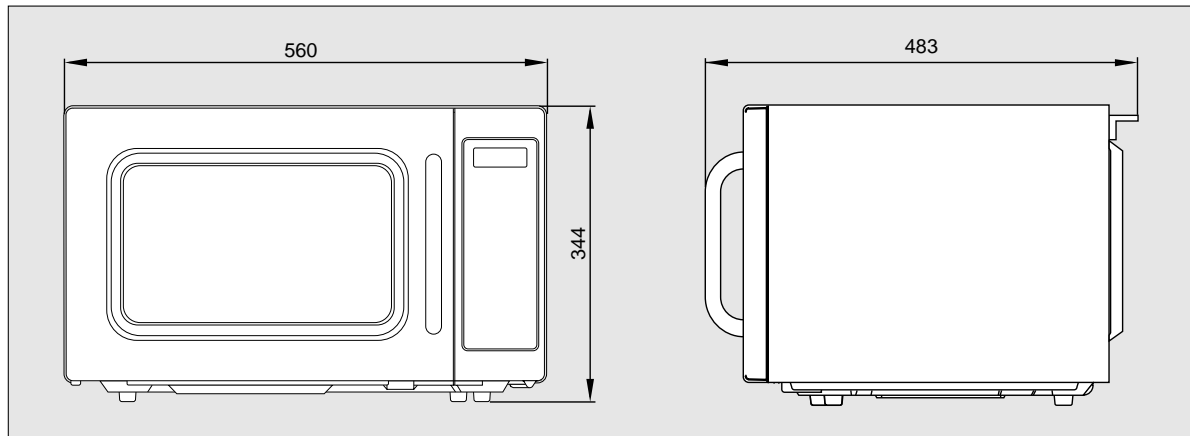

IMPORTANT

The wires in this mains lead fitted to this appliance are coloured in accordance with the following code.

Green-and-yellow : Earth
 Blue : Neutral
 Brown : Live

As the colours of the wires in the mains lead of this appliance may not correspond with the coloured markings identifying the terminals in your plug, proceed as follows: the wire which is coloured green-and-yellow must be connected to the terminal in the plug which is marked with the letter 'E', the earth symbol or coloured green-and-yellow. The wire which is coloured blue must be connected to the terminal which is marked with the letter 'N' or coloured black.

The wire which is coloured brown must be connected to the terminal which is marked with the letter 'L' or coloured red.

WARNING: This appliance must be earthed.

IMPORTANT SAFETY INSTRUCTIONS

READ CAREFULLY AND KEEP FOR FUTURE REFERENCE

WARNING : To prevent fire, burns, electric shock and other warnings:

Listed below are, as with all appliances, certain rules to follow and safeguards to assure high performance from this oven:

1. Do not use the oven for any reason other than food preparation, such as for drying clothes, paper, or any other nonfood items or for sterilizing purposes.
2. Do not use the oven when empty, this could damage the oven.
3. Do not use the oven cavity for any type of storage, such as papers, cookbook, cookware, etc.
4. Make sure you remove caps or lids prior to cooking when you cook food sealed in bottles.
5. Do not put foreign material between the oven surface and door. It could result in excessive leakage of microwave energy.
6. Do not use recycled paper products for cooking. They may contain impurities which could cause sparks and/or fires when used during cooking.
7. Do not pop popcorn unless popped in a microwave approved popcorn popper or unless it's commercially packaged and recommended especially for microwave ovens. Microwave popped corn produces a lower yield than conventional popping; there will be a number of unpopped kernels. Do not use oil unless specified by the manufacturer.
8. Do not cook any food surrounded by a membrane, such as egg yolks, potatoes, chicken livers, etc., without first piercing them several times with a fork.
9. Do not pop popcorn longer than the manufacturer's directions. (popping time is generally below 3 minutes). Longer cooking does not yield more popped corn, it can cause scorchings and fire. Also, the cooking tray can become too hot to handle or may break.
10. If smoke is observed, switch off or unplug the appliance and keep the door closed in order to stifle any flames.
11. When heating food in plastic or paper containers, keep an eye on the oven due to the possibility of ignition.
12. The contents of feeding bottles and baby food jars shall be stirred or shaken and the temperature checked before consumption, in order to avoid burns.
13. Always test the temperature of food or drink which has been heated in a microwave oven before you give it to somebody, especially to children or elderly people. This is important because things which have been heated in a microwave oven carry on getting hotter even though the microwave oven cooking has stopped.
14. Eggs in their shell and whole hard-boiled eggs should not be heated in microwave ovens since they may explode, even after microwave heating has ended;
15. Keep the waveguide cover clean at all times. Wipe the oven interior with a soft damp cloth after each use. If you leave grease or fat anywhere in the cavity it may overheat, smoke or even catch fire when next using the oven.
16. Never heat oil or fat for deep frying as you cannot control the temperature and doing so may lead to overheating and fire.
17. Microwave heating of beverages can result in delayed eruptive boiling, therefore care must be taken when handling the container.
18. Do not cover or block any openings on the appliance.
19. Do not store this appliance outdoors. Do not use this product near water - for example, near a kitchen sink, in a wet basement, or near a swimming pool, and the like.
20. Keep cord away from heated surfaces.
21. Do not let cord hang over edge of table or counter.
22. The oven should be cleaned regularly and any food deposits removed
23. Failure to maintain the oven in a clean condition could lead to deterioration of the surface that could adversely affect the life of the appliance and possibly result in a hazardous situation.

SAVE THESE INSTRUCTIONS

FEATURES DIAGRAM

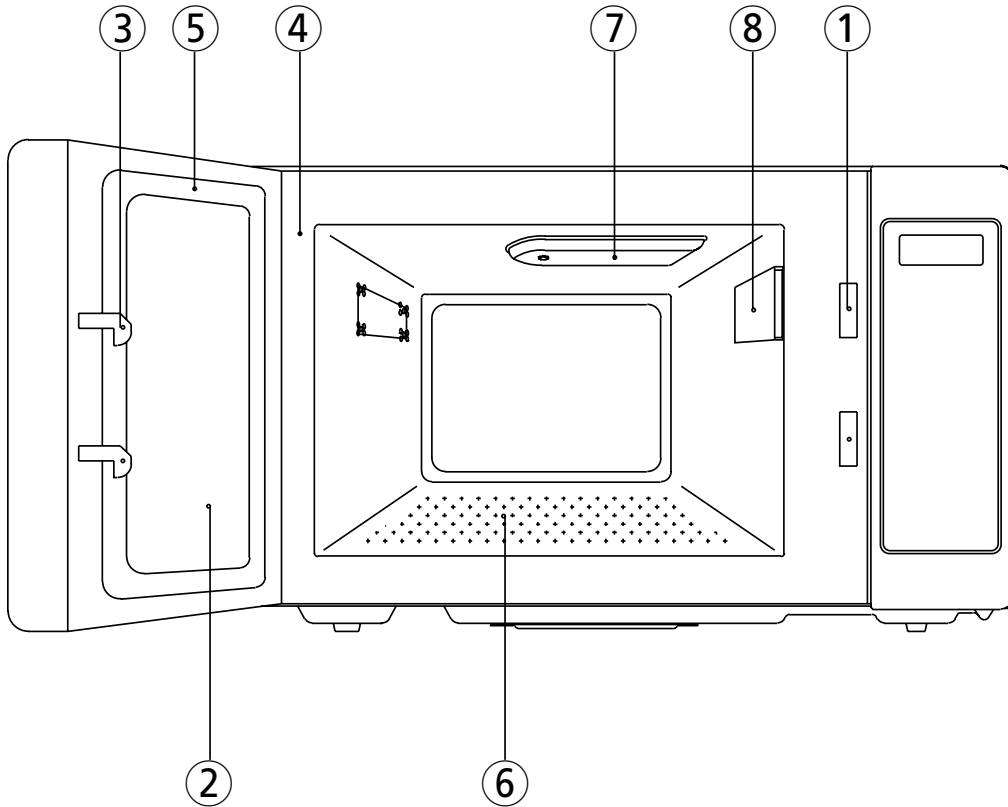

- ① **Safety Interlock System.**
- ② **Door Viewing Screen** - Allows viewing of food. The screen is designed so that light can pass through, but not the microwave.
- ③ **Door Hook** - When door is closed, it will automatically shut off. If the door is opened while the oven is operating, magnetron will immediately stop operating.
- ④ **Oven Cavity.**
- ⑤ **Door Seal** - Door seal maintains the microwave energy within the oven cavity and prevents microwave leakage.
- ⑥ **Plate Tray** - Made of special heat resistant ceramic. Food in a proper receptacle is placed on this plate for cooking.
- ⑦ **Stirrer Cover** - This is located on the ceiling with the stirrer fan.
- ⑧ **Inlet cover** - Protect the air hole from splashes of cooking foods.

FEATURES DIAGRAM (continued)

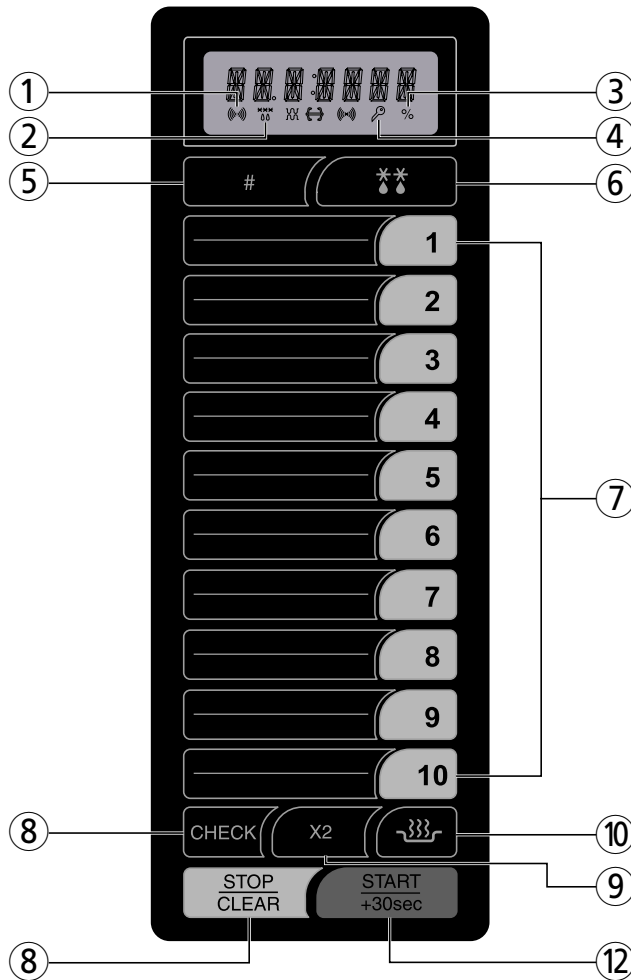

① MICROWAVE indicator, showing microwaving in progress.

② DEFROST indicator, showing defrosting in progress.

③ PERCENTAGE of power indicator.

④ CHILD LOCK indicator.

⑤ PROGRAM - Used to save cooking data.

⑥ DEFROST - Used to defrost foods for time.

⑦ TIME SET PAD - Used to set the cooking time.

⑧ CHECK - Used to check cooking data.

⑨ DOUBLE QUANTITY - Used to extend programmed cooking time.

⑩ POWER - Used to set power level.

⑪ STOP/CLEAR - Used to stop the oven operation or to delete the cooking data.

⑫ START /+30 SEC - Used to start the oven and also used to set a reheat time.

OPERATION PROCEDURE

This section includes useful information about oven operation.

1. Plug power supply cord into a standard 3- pronged 240V AC 50Hz power outlet.
2. After placing the food in a suitable container, open the oven door and put it on the plate tray.
3. Shut the door. Make sure that it is firmly closed.

- 1 The oven light is on when the microwave oven is operating or the door is opened.
- 2 The oven door can be opened at any time during operation by opening the door. The oven will automatically shut off.
- 3 Each time a pad is touched, a BEEP will sound to acknowledge the touch.
- 4 The oven automatically cooks on full power unless set to a lower power level.
- 5 The display will show ":0" when the oven is plugged in.
- 6 When the STOP/CLEAR pad is touched during the oven operation, the oven stops cooking and all information retained.
To erase all information, touch the STOP/CLEAR pad once more. If the oven door is opened during the oven operation, all information is retained.
- 7 If the START pad is touched and the oven does not operate, check the area between the door and door seal for obstructions and make sure the door is closed securely.
The oven will not start cooking until the door is completely closed or the program has been reset.

Make sure the oven is properly installed and plugged into the electrical outlet.

WATTAGE OUTPUT CHART

- The power-level is set by touching the POWER pad. The chart shows the display, the power level and the percentage of power.

Touch POWER pad	Power Level (Display)	Approximate Percentage of Power
once	100	100%
twice	80	80%
3 times	60	60%
4 times	40	40%

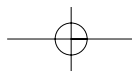

CONTROLS

TIME DEFROSTING

When DEFROST is selected, the automatic cycle divides the defrosting time into periods of alternating defrost and stand times by cycling on and off.



1. Touch  pad.

The DEFROST indicator lights and " : 0" is displayed.

2. Touch number pads for the desired defrosting time.

The display will show the numbers you pressed in the order you touched.

3. Touch START pad.

NOTE: Your oven can be programmed for 59 minutes 99 seconds.(59:99)

When you touch START pad, the DEFROST indicator lights to show the oven is in the DEFROST mode. The display counts down the time to show you how much defrosting time is left in the DEFROST mode. The oven beeps during the defrosting cycle to signal that the food needs to be turned or rearranged. When the defrosting time ends, you will hear 3 beeps.

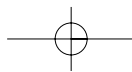

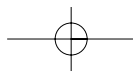

COOKING IN ONE STAGE



1. Touch  pad.
(Select desired power level.)

The MICROWAVE and % indicators light.
The display will show what you touched.

2. Touch the number pads for the
cooking time.

This example shows power level 60.
The display will show the numbers you
pressed in the order you touched.

NOTE: Your oven can be programmed
for 59 minutes 99 seconds.
(59:99)
but, in case of full power(100%),
maximum time is 20 minutes 00
seconds. (20:00)

3. Touch START pad.

When you touch START pad, the MICROWAVE indicator lights to show the oven is cooking.
The display counts down the time to show how much cooking time is left. When the cooking time ends, you
will hear 3 beeps.

NOTE: Using lower power levels increases the cooking time which is recommended for foods such
as cheese, milk and slow cooking of meats.

NOTE: The cooling fan may operate to prevent the oven being overheated.

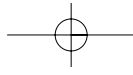

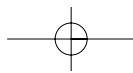

MEMORY FUNCTION

This microwave oven has 20 programmable pads (1~20).



- | | |
|----------------------------------------------------------|-------------------------------------------------------|
| 1. Touch # pad. | The display will show “ # ”. |
| 2. Touch the number pads. ex)5 | The display will show “PROG-05”. |
| 3. Touch POWER pad. (Select desired power level.) | The MICROWAVE and % indicators light. |
| 4. Touch the NUMBER pads for cooking time. | The display will show what you touched. |
| 5. Touch START pad to save cooking time and power level. | The display will show “STAGE-2” and long beep sounds. |
| 6. Touch STOP/CLEAR pad. | When you touch STOP/CLEAR pad, MEMORY function ends. |

NOTE 1: If you want cooking in two or three stage, repeat step 3~5 once or twice, and display will show “STAGE-2” or “STAGE-3”.
After touching START pad to save cooking time and power level in 3-stage, you can see “ - END - ” on the display.

NOTE 2: In case of original set, number 1~10 is programmed but cooking data is changeable later.
And number 11~20 is not programmed, so you will save cooking data.

After programming is finished, just touch the NUMBER pad of the memory number you want to select. Then the oven will automatically start heating according to the pre-programmed cooking time and power level.

* Preprogrammed Cooking Times and Power Level

Pad	Cooking Time	Power Level
1	20 sec.	100 %
2	40 sec.	100 %
3	1 min.	100 %
4	1:30 min.	100 %
5	2 min.	100 %
6	3 min.	100 %
7	4 min.	100 %
8	6 min.	100 %
9	8 min.	100 %
10	10 min.	100 %

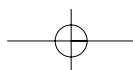

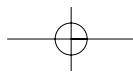

+30 SEC

+30 SEC allows you to reheat for 30 seconds at 100% (full power) by simply touching the +30 SEC pad.

By repeatedly touching the +30 SEC pad, you can also extend reheating time to 5 minutes by 30 second increments.



1. Touch +30 SEC pad.

When you touch +30 SEC, ":30" is displayed.

The oven will start immediately. It will add 30 seconds to the time counting down each time the pad is touched.

CHECK FUNCTION

This feature allows you to check the programmed cooking time and power level.



1. Touch CHECK pad.
2. Touch the NUMBER pads which you want confirmation.
ex)5

The display will show "CHECK".

The display will show "PROG-05".

The display will show cooking time, power level each stage.

If you want to end, touch STOP/CLEAR pad.

DOUBLE QUANTITY FUNCTION

This feature allows you to extend programmed cooking time twice temporarily.

But, the extended cooking time can't exceed maximum cooking time.

Maximum cooking time of this oven is 59 minutes 99 seconds except full power.

In case of full power (100%), maximum cooking time is 20 minutes 00 seconds.



1. Touch X2 pad.
2. Touch the NUMBER pads which is programmed. ex)5

The display will show "X2".

The display will show "PROG-05".
After 1.5 seconds, the oven automatically start cooking.

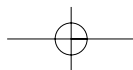

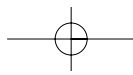

CHILD SAFETY LOCK

The safety lock prevents unwanted oven operation such as by small children.
To set, press and hold STOP/CLEAR for 3 seconds, LOCK indicator lights.
To cancel, press and hold STOP/CLEAR for 3 seconds, LOCK indicator goes off.

POWER SAVE MODE

This function is used for saving energy.
To set, press and hold CHECK pad for 3 seconds. The oven will beep and nothing appears in the display. Now the oven is in power save mode.
To operate the oven in power save mode, press any pad. Then “ : 0” will show and the operation of all function key will be same as in normal mode.
But, if there is no operation within 10 seconds in clear mode or while manipulating the key, all the contents of display will disappear.
To cancel, after press any pad, press and hold CHECK pad for 3 seconds.
Then the oven is again available for normal use.

MUTE FUNCTION

To set, press and hold “X2” pad for 3 seconds.
The display will show “MUTE” for 1 second.
Then you will not hear beeps, when you press any pad.
To cancel, press and hold “X2” pad for 3 seconds.

TO STOP THE OVEN WHILE THE OVEN IS OPERATING

1. Press STOP/CLEAR pad.
 - You can restart the oven by touching START pad.
 - Touch STOP/CLEAR once more to erase all instructions.
 - You must enter in new instructions.
2. Open the door.
 - You can restart the oven by closing the door and touching START.

NOTE: Oven stops operating when door is opened.

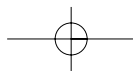

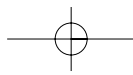

COOKING INSTRUCTIONS

Only use utensils that are suitable for use in microwave ovens.

UTENSILS TEST

Place the utensil in question next to a glass measure filled with water, in the microwave oven. Microwave at high power for 1-2 minutes. If the water heats up, but the utensil remains cool, the utensil is microwave-safe. However if the utensil becomes warm, microwaves are being absorbed by the utensil and it should not be in the microwave oven. You probably have many items on hand in your kitchen right now that can be used as cooking equipment in your microwave oven. Read through the following checklist.

COOKING UTENSILS

Recommended Use

- **Glass and glass-ceramic bowls and Dishes** - Use for heating or cooking.
- **Microwave browning dish** - Use to brown the exterior of small items such as steaks, chops, or pancakes. Follow the directions provided with you browning dish.
- **Microwaveable plastic wrap** - Use to retain steam. Leave a small opening for some steam to escape and avoid placing it directly on the food.
- **Wax paper** - Use as a cover to prevent spattering.
- **Paper towels, and napkins** - Use for short term heating and covering; they absorb excess moisture and prevent spattering. Do not use recycled paper towels, which may contain metal and can catch fire.
- **Thermometers** - Use only those labeled "Microwave Safe" and follow all directions. Check the food in several places. Conventional thermometers may be used once the food has been removed from the oven.
- **Microwave cling film, microwave roasting bags** - Microwave cling film and bags must be vented for steam to escape, pierce in 4~5 places. Do not use plastic or metal ties as they may melt or catch fire due to electrical 'arcing'.

Limited Use

- **Aluminum foil** - Use narrow strips of foil to prevent overcooking of exposed areas. Using too much foil can damage your oven, so be careful.
- **Ceramic, porcelain, and stoneware** - Use these if they are labeled "Microwave Safe." If they are not labeled, test them to make sure they can be used safely. Never use dishes with metallic trim.
- **Plastic** - Use only if labeled "Microwave Safe." Other plastics can melt.
- **Thin plastic, paper, straw and wooden containers** - Always attend the oven closely. Look at the oven from time to time when cooking or reheating food in disposable containers of plastic, paper or other combustible material. Only use for warming food. Pay special attention as over-heating may cause a fire in your oven.

Not Recommended

- **Glass jars and bottles** - Regular glass is too thin to be used in a microwave, and can shatter.
- **Paper bags** - These are a fire hazard, except for popcorn bags that are designed for microwave use.
- **Styrofoam plates and cups** - These can melt and leave an unhealthy residue on food.
- **Plastic storage and food containers** - Containers such as margarine tubs can melt in the microwave.
- **Metal utensils** - These can damage your oven. Remove all metal before cooking.

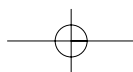

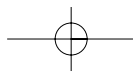

MICROWAVING PRINCIPLES

Microwave energy has been used in this country to cook and reheat food since early experiments with RADAR in World War II. Microwaves are present in the atmosphere all the time, both naturally and manmade sources. Manmade sources include radar, radio, television, telecommunication links and car phones.

HOW MICROWAVES COOK FOOD

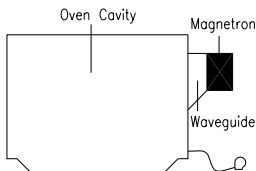

In a microwave oven, electricity is converted into microwave by the **MAGNETRON**.

► TRANSMISSION

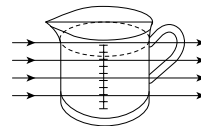

Then they pass through the cooking containers to be absorbed by the water molecules in the food, all foods contain water to a more or lesser extent.

► REFLECTION

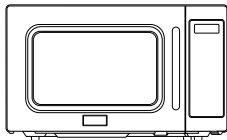

The microwaves bounce off the metal walls and the metal door screen.

► ABSORPTION

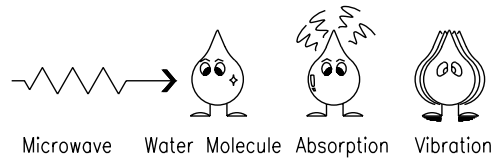

The microwaves cause the water molecules to vibrate which causes **FRICTION**, i.e. **HEAT**. This heat then cooks the food. Microwaves are also attracted to fat and sugar particles, and foods high in these will cook more quickly. Microwaves can only penetrate to a depth of 1½ - 2 inches(4-5cm) and as heat spreads through the food by conduction, just as in a traditional oven, the food cooks from the outside inwards.

CONVERSION CHARTS

WEIGHT MEASURES		VOLUME MEASURES		SPOON MEASURES	
15 g	1/2 oz.	30 ml	1 fl.oz.	1.25 ml	1/4 tsp
25 g	1 oz.	100 ml	3 fl.oz.	2.5 ml	1/2 tsp
50 g	2 oz.	150 ml	5 fl.oz. (1/4 pt)	5 ml	1 tsp
100 g	4 oz.	300 ml	10 fl.oz. (1/2 pt)	15 ml	1 tbsp
175 g	6 oz.	600 ml	20 fl.oz. (1pt)		
225 g	8 oz.				
450 g	1 lb.				

FLUID MEASUREMENTS		
1 Cup	= 8 fl.oz.	= 240 ml
1 Pint	= 16 fl.oz. (UK 20 fl.oz.)	= 480 ml (UK 560 ml)
1 Quart	= 32 fl.oz. (UK 40 fl.oz.)	= 960 ml (UK 1120 ml)
1 Gallon	= 128 fl.oz. (UK 160 fl.oz.)	= 3840 ml (UK 4500 ml)

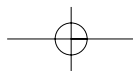

COOKING TECHNIQUES

STANDING TIME

Dense foods e.g. meat, jacket potatoes and cakes, require standing time (inside or outside of the oven) after cooking, to allow heat to finish conducting to cook the center completely. Wrap meat joints and jacket potatoes in aluminium foil while standing. Meat joints need approx. 10-15 minutes, jacket potatoes 5 minutes. Other foods such as plated meal, vegetables, fish etc require 2-5 minutes standing. After defrosting food, standing time should also be allowed. If food is not cooked after standing time, return to the oven and cook for additional time.

MOISTURE CONTENT

Many fresh foods e.g. vegetables and fruit, vary in their moisture content throughout the season, particularly jacket potatoes. For this reason cooking times may have to be adjusted. Dry ingredients e.g. rice, pasta, can dry out during storage so cooking times may differ.

DENSITY

Porous airy foods heat more quickly than dense heavy foods.

CLING FILM

Cling film helps keep the food moist and the trapped steam assists in speeding up cooking times. Pierce before cooking to allow excess steam to escape. Always take care when removing cling film from a dish as the build-up of steam will be very hot.

SHAPE

Even shapes cook evenly. Food cooks better by microwave when in a round container rather than square.

SPACING

Foods cook more quickly and evenly if spaced apart. NEVER pile foods on top of each other.

STARTING TEMPERATURE

The colder the food, the longer it takes to heat up. Food from a fridge takes longer to reheat than food at room temperature.

LIQUIDS

All liquids must be stirred before and during heating. Water especially must be stirred before and during heating, to avoid eruption. Do not heat liquids that have previously been boiled. DO NOT OVERHEAT.

TURNING & STIRRING

Some foods require stirring during cooking. Meat and poultry should be turned after half the cooking time.

ARRANGING

Individual foods e.g. chicken portions or chops, should be placed on a dish so that the thicker parts are towards the outside.

QUANTITY

Small quantities cook faster than large quantities, also small meals will reheat more quickly than large portions.

PIERCING

The skin or membrane on some foods will cause steam to build up during cooking. These foods must be pierced or a strip of skin should be peeled off before cooking to allow the steam to escape. Eggs, potatoes, apples, sausages etc, will all need to be pierced before cooking. DO NOT ATTEMPT TO BOIL EGGS IN THEIR SHELLS.

COVERING

Cover foods with microwave cling film or a lid. Cover fish, vegetables, casseroles, soups. Do not cover cakes, sauces, jacket potatoes or pastry items.

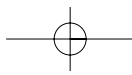

DEFROSTING GUIDE

GENERAL INFORMATION

- ⇒ Put the food on a microwave rack (roasts, bone-in pieces) or in a microwave casserole (small pieces such as cubes or strips) or weigh at home on a kitchen scale. Round number to the nearest tenth of a pound and choose that number with each item pads.
- ⇒ The shape of food items, especially larger ones, will vary affect the way defrost. Always check the status after the standing time. Fish, seafood and poultry should still be somewhat icy in the center the held under cold running water to finish defrosting. If more time is needed, use DEFROST by time to add time in small increments.
- ⇒ Halfway through the defrosting process, a series of beeps will indicate that it is time to change the position of the item being defrosted. The includes turning over or rotating the item, separating defrosted pieces or sections, or shielding.
- ⇒ Shielding means to use a 2-inch strip of aluminum foil to protect thinner or unevenly shaped part from beginning to cook. Microwave energy will not penetrate the foil. Some rules apply to the use of foil:
Do not let the foil pieces touch each other or the sides of the microwave oven.
Be sure that all ends are touched under and lie flat to the food.
Remember to adjust foil when a item is turned over and cover with wax paper.
- ⇒ To prepare food for freezer storage(and later defrosting), wrap tightly in moisture proof packaging. If using freezer plastic bags, be sure to let all the air out to prevent freezer bump on the food. Package so that food is as evenly shaped as possible ease in defrosting

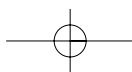
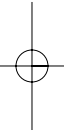
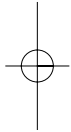

DEFROSTING CHART

Item and Weight	Defrosting Time	Standing Time	Special Techniques
BEEF Mineed beef 454g (1 lb.)	5-7 min.	5-7 min.	Break apart and remove thawed portions with fork.
Stew Meat 681 (1 ¹ / ₂ lbs.)	6-8 min.	5-7 min.	Separate and rearrange once.
Loin Roast 907g (2 lbs.)	10-12 min.	5-7 min.	Turn over after half the time. Shield as needed.
Patties 4 (113g (4 oz.))	2-4 min.	5-7 min.	Turn over after half the time.
PORK Loin Roast 907g (2 lbs.)	8-10 min.	7-10 min.	Turn over after half the time. Shield as needed.
Spareibs 454g (1 lb.)	3-5 min.	5-7 min.	Separate and rearrange once.
Chops 4 (142g (5 oz.))	3-5 min.	5-7 min.	Separate and turn over once.
Minced 454g (1 lb.)	4-6 min.	5-7 min.	Beat apart and remove thawed portions with fork.
POULTRY Whole Chicken 1134g (2 ¹ / ₂ lbs.)	10-14 min.	10-15 min.	Breat side down. Turn over after half the time. Shield as needed.
Chicken Breasts 454g (1 lb.)	5-7 min.	5-7 min.	Separate and rearrange once.
Fryer Chicken (cut up) 907g (2 lbs.)	7-9 min.	5-7 min.	Separate and rearrange once.
Chicken Thighs 681g (1 ¹ / ₂ lbs.)	6-10 min.	5-7 min.	Separate and rearrange once.
FISH & SEAFOOD Whole Fish 454g (1 lb.)	2-3 min.	5-7 min.	Turn over after half the time. Shield as needed.
Fish Fillets 681g (1 ¹ / ₂ lb.)	3-4 min.	5-7 min.	Separate and turn over once.
Shrimp 227g (1/2 lb.)	1-2 min.	5-7 min.	Separate and rearrange once.

* The times are approximate because freezer temperatures vary.

COOKING CHART

Check time per 1lb. in chart below and multiply by the weight of the item.

MEAT		
ITEM	POWER LEVEL	COOKING TIMER PER 500g
Beef		
Standing/rolled Rib - Rare	80	6-8 min.
- Medium	80	7-9 min.
- well done	80	8-10 min.
Ground Beef(to brown for casserole)	100	5-7 min.
Hamburgers, Fresh or defrosted (4 oz. Each)		
2 patties	100	2-3 min.
4 patties	100	3-4 min.
Pork		
Loin, Leg	80	10-12 min.
Bacon		
4 slices	100	2-3 min.
6 slices	100	3-4 min.

NOTE: The above times should be regarded only as a guide. Allow for difference in individual tastes and preferences. The times may vary due to the shape, cut, and composition of the meat.

POULTRY		
ITEM	POWER LEVEL	COOKING TIMER PER 500g
Chicken		
Whole	100	6-9 min.
Breast(boned)	80	4-6 min.
portions	80	5-7 min.
Turkey		
Whole	100	8-11 min.

NOTE: The above times should be regarded only as a guide. Allow for difference in individual tastes and preferences. The times may vary due to the shape and composition of the food.

FRESH FISH				
ITEM	POWER LEVEL	COOKING TIME PER POUND	METHOD	STANDING TIME
Fish Fillets	100	3-4 min.	Add 15-30 ml(1-2 Tbsp)	2-3 min.
Whole Mackerel, Cleaned and Prepared	100	3-4 min.	-	3-4 min.
Whole Trout, Cleaned and Prepared	100	4-6 min.	-	3-4 min.
Salmon Steaks	100	4-6 min.	Add 15-30 ml(1-2 Tbsp)	3-4 min.

VEGETABLE					
ITEM	POWER LEVEL	PREPARATION	QUANTITY	COOKING TIME	STANDING TIME
Artichokes, fresh	100	Whole	4(8 oz. each)	5-7 min.	5 min.
Artichokes, frozen	100	Hearts	250g(9 oz. pkg)	6-8 min.	5 min.

VEGETABLE					
ITEM	POWER LEVEL	PREPARATION	QUANTITY	COOKING TIME	STANDING TIME
Asparagus, fresh	100	1 1/2-in.pieces	500g(1 lb.)	3-5 min.	3 min.
Asparagus, frozen	100	Whole spears	280g(10 oz. pkg)	5-7 min.	3 min.
Broccoli, fresh	100	Spears	500g(1 lb.)	3-5 min.	-
Broccoli, frozen	100	Whole or cut	280g(10 oz. pkg)	5-7 min.	3 min.
Brussels sprouts, fresh	100	Whole	280g(10 oz. tub)	3-5 min.	-
Brussels sprouts, frozen	100	Whole	280g(10 oz. pkg)	5-7 min.	3 min.
Carrots, fresh	100	1/2-in.slices	500g(1 lb.)	4-6 min.	3 min.
Carrots, frozen	100	Sliced	280g(10 oz. pkg)	3-4 min.	3 min.
Cauliflower, frozen	100	florets	280g(10 oz. pkg)	3-4 min.	3 min.
Celery, fresh	100	1/2-in.slices	500g(1 lb.)	3-5 min.	5 min.
Corn, fresh	100	on cob, husked	4 ears	5-7 min.	5 min.
Corn, frozen	100	on cob, husked	4 ears	5-7 min.	5 min.
	100	whole kernel	280g(10 oz. pkg)	4-6 min.	3 min.
Eggplant, fresh	100	cubed	500g(1 lb.)	3-5 min.	3 min.
	100	whole, pierced	500~700g(1-1 1/2 lb.)	4-6 min.	5 min.
Leeks fresh	100	whole, ends	500g(1 lb.)	4-6 min.	5 min.
Lima beans, frozen	100	whole	280g(10 oz. pkg)	4-6 min.	3 min.
Mixed vegetables frozen	100	-	280g(10 oz. pkg)	4-6 min.	3 min.
Mushrooms, fresh	100	sliced	500g(1 lb.)	2-3 min.	3 min.
Okra, frozen	100	sliced	280g(10 oz. pkg)	4-6 min.	5 min.
Onions, fresh	100	whole, peeled	8-10 small	5-7 min.	5 min.
Pea pods(snow peas), frozen	100	whole	170g(6 oz. pkg)	2-3 min.	3 min.
Peas and carrots	100	-	280g(10 oz. pkg)	2-3 min.	3 min.
Parsnips, fresh	100	cubed	500g(1 lb.)	4-6 min.	5 min.
Potatoes, white or sweet, fresh	100	whole	4(6 oz. each)	15-17 min.	3 min.
	100	whole	8(6 oz. each)	18-20 min.	5 min.
Squash, summer, fresh	100	1/2-in.slices	500g(1 lb.)	3-5 min.	3 min.
Squash, summer, frozen	100	sliced	280g(10 oz. pkg)	3-5 min.	3 min.
Squash, winter, fresh	100	whole, pierced	700g(1 1/2 lbs.)	6-8 min.	5 min.
Squash, winter, frozen	100	whipped	340g(12 oz. pkg)	4-6 min.	3 min.
Succotash, frozen	100	-	280g(10 oz. pkg)	3-5 min.	3 min.
Turnips	100	cubed	4 cups	4-6 min.	3 min.

REHEATING CHART

ITEM	QUANTITY	POWER LEVEL	COOKING TIME	SPECIAL INSTRUCTION
Appetizers (bite size)	2 servings	100	1-2 min.	Heat 12 at time on paper towel lined paper plate or microwave oven roasting rack
Breakfast entrée	110~140g(4-5 oz.)	100	1-2 min.	If containers is 3/4-inch deep, remove foil cover and replace foil tray in original box. For containers more then 3/4-inch deep, remove food to similar size glass container; heat, covered. If no top crust stir occasionally.
Entrée	250g(8-9 oz.)	100	6-8 min.	
Regular TV-style dinner	600g(21 oz.)	100	10-12 min.	
Hearty TV-style dinner	300g(11 oz.)	100	4-6 min.	
	480g(17 oz.)	100	5-8 min.	

ITEM	QUANTITY	POWER LEVEL	COOKING TIME	SPECIAL INSTRUCTION
Fried chicken	2 pieces	100	1-2 min.	Arrange, on paper tower lined paper plate, covered with paper tower.
	4 pieces	100	2-4 min.	
	6 pieces	100	3-5 min.	
Fried fresh fillets	2 fillets	100	1-2 min.	
	4 fillets	100	2-4 min.	
Pizzas (sliced)	1	100	1-2 min.	Arrange on microwave oven roasting rack.
	2	100	2-3 min.	
	4	100	3-6 min.	
Pouch dinners	140~160g(5-6 oz.)	100	2-3 min.	Pierce pouch. Set on plate. Turn over halfway through cooking.
	280~300g(10-11 oz.)	100	5-7 min.	
Bagels	2	60	1-2 min.	Each individually wrapped in paper toweling (for 1-2) or arrange on paper plate, cover with paper toweling.
	4	60	2-4 min.	
Danish	1	60	1/2-1 min.	
	2	60	1-2 min.	
	4(6 oz. pkg)	60	2-3 min.	
	6(13 oz. pkg)	60	3-4 min.	
Dinner rolls	6	60	1-2 min.	
Hard rolls	1(1-1 ¹ / ₄ oz.)	60	1/2-1 min.	
	2	60	1-2 min.	
	4	60	2-3 min.	
Frozen Juice	170g(6 oz.)	100	1-2 min.	Remove lid. If container is foil lined transfer to a pitcher or open carton. Let stand after defrosting.
Concentrates	340g(12 oz.)	100	2-3 min.	
Non-Dairy creamer	450g(16 oz.)	60	6-8 min.	Let stand after defrosting.
Pancake	280g(10 oz.)	60	3-5 min.	
Frozen vegetables	160g(6 oz.)	60	5-7 min.	Pierce box, set on plate. If box is foil wrapped, remove foil. If vegetables are in pouch, pierce pouch. Let stand 5 min.
	280g(10 oz.)	60	6-10 min.	
Cheese cake	500g(17 oz.)	60	3-4 min.	Remove from original container. Arrange on a serving plate. Let stand 5 minutes after cooking(to defrost). Add an additional 1-2 minutes to serve warm.
Brownies	360g(13 oz.)	60	1-3 min.	
Pound cake	300g(10 ³ / ₄ oz.)	60	1-2 min.	
Coffee cake	300~340g(11-12 oz.)	60	2-3 min.	

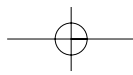

CARE OF YOUR MICROWAVE OVEN

- 1 Turn the oven off before cleaning.
- 2 Keep the inside of the oven clean. When food spatters or spilled liquids adhere to **oven walls, plate tray, stirrer cover** wipe with a damp cloth. Mild detergent may be used if the oven gets very dirty. The use of harsh detergent or abrasives is not recommended.
- 3 The outside oven surface should be cleaned with soap and water, rinsed and dried with a soft cloth. To prevent damage to the operating parts inside the oven, water should not be allowed to seep into the ventilation openings.
- 4 If the Control Panel becomes wet, clean with a soft, dry cloth. Do not use harsh detergents or abrasives on Control Panel.
- 5 If steam accumulates inside or around the outside of the oven door, wipe with a soft cloth. This may occur when the microwave oven is operated under high humidity conditions and in no way indicates malfunction of the unit.

IMPORTANT CAUTIONS

1. Do not operate after removed food.
2. Do not operate the oven without **stirrer cover** in place.
3. Do not remove the **stirrer cover** and **plate tray**.

CARE AND CLEANING

Although your oven is provided with safety features, it is important to observe the following:

1. It is important not to defeat or tamper with safety interlocks.
2. Do not place any object between the oven front face and the door or allow residue to accumulate on sealing surfaces. Wipe the sealing area frequently with a mild detergent, rinse and dry. Never use abrasive powders or pads.
3. When opened, the door must not be subjected to strain, for example, a child hanging on an opened door or any load could cause the oven to fall forward to cause injury and also damage to the door. Do not operate the oven if it is damaged, until it has been repaired by a competent service technician. It is particularly important that the oven closes properly and that there is no damage to the:
 - i) Door(bent)
 - ii) Hinges and Hooks(broken or loosened)
 - iii) Door seals and sealing surfaces.
4. The oven should not be adjusted or repaired by anyone except a properly competent service technician.
5. The oven should be cleaned regularly and any food deposits removed;
6. Failure to maintain the oven in a clean condition could lead to deterioration of the surface that could adversely affect the life of the appliance and possibly result in a hazardous situation.

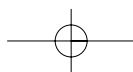

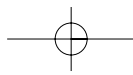

USE YOUR MICROWAVE OVEN SAFELY

General Use

Do not attempt to defeat or tamper with safety interlocks.

Do not place any object between the oven front frame and the door or allow residue to build up on sealing

surfaces. Wipe with a mild detergent, rinse and dry. Never use abrasive powders or pads.

Do not subject the oven door to strain or weight such as a child hanging on an open door.

This could cause the oven to fall forward resulting in injury to you and damage to the oven.

Do not operate the oven if door seals or sealing surfaces are damaged; or if door is bent; or if hinges are loose or broken.

Do not operate the oven empty. This will damage the oven.

Do not attempt to dry clothes, newspapers or other materials in the oven. They may catch on fire.

Do not use recycled paper products as they may contain impurities which may cause sparks or fires.

Do not hit or strike the control panel with hard objects. This can damage the oven.

Food

Always use the minimum recipe cooking time. It is better to undercook rather than overcook foods.

Undercooked foods can be returned to the oven for more cooking. If food is overcooked, nothing can be done.

Heat small quantities of food or foods with low moisture carefully. These can quickly dry out, burn or catch on fire.

Do not heat eggs in the shell. Pressure may build up and eggs can explode.

Potatoes, apples, egg yolks and sausages are examples of food with non-porous skins.

These must be pierced before cooking to prevent bursting.

Do not attempt to deep fat fry in your microwave oven.

Always stir liquids before heating. Heated liquids can erupt, if not mixed with air.

Do not leave the oven unattended while popping corn.

Do not pop corn in a paper bag unless it is the commercially prepared Microwave Popcorn product. The kernels can overheat and ignite a brown paper bag.

Do not put packaged Microwave Popcorn bags directly on the oven tray. Place the package on a microwave safe glass or ceramic plate to avoid overheating and cracking the oven tray.

Do not exceed the Microwave Popcorn manufacturers' suggested popping time. Longer popping does not yield more popcorn but it can result in scorch, burn or fire. Remember, the Popcorn bag and tray can be too hot to handle. Remove with caution and use pot holders.

ARCING

If you see arcing, open the door and correct the problem.

Arcing is the microwave term for sparks in the oven.

Arcing is caused by:

- Metal or foil touching the side of the oven.
- Foil not molded to food (upturned edges act like antennas).
- Metal, such as twist-ties, poultry pins, or gold rimmed dishes, in the microwave.
- Recycled paper towels containing small metal pieces being used in the microwave.

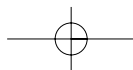

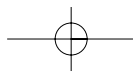

BEFORE YOU CALL FOR SERVICE

Refer to following checklist, you may prevent an unnecessary service call.

- * The oven doesn't work;
 1. Check that the power cord is securely plugged in.
 2. Check that the door firmly closed.
 3. Check that the cooking time is set.
 4. Check for a blown circuit fuse or tripped main circuit breaker in your house.

- * Sparking in the cavity;
 1. Check that utensils are metal containers or dishes with metal trim.
 2. Check that metal skewers touch the interior walls.

If there is still a problem, contact the service station.
A list of these stations is included in the oven.

DO NOT ATTEMPT TO SERVICE THE OVEN YOURSELF!

QUESTIONS AND ANSWERS

- * Q : I accidentally ran my microwave oven without any food in it. Is it damaged?
A : Running the oven empty for a short time will not damage the oven.
However, it is not recommended.

- * Q : Can I open the door when the oven is operating?
A : The door can be opened anytime during the cooking operation. Then microwave energy will be instantly switched off and the time setting will maintain until the door is closed and START is touched.

- * Q : Why do I have moisture in my microwave oven after cooking?
A : The moisture on the side of your microwave oven is normal. It is caused by steam form cooking food heating the cool oven surface.

- * Q : Dose microwave energy pass through the viewing screen in the door?
A : No. The metal screen bounces back the energy to the oven cavity. The holes are made to allow light to pass through. They do not let microwave energy pass through.

- * Q : Why do eggs sometimes pop?
A : When baking or poaching eggs, the yolk may pop due to steam build-up inside the yolk membrane. To prevent this, simply pierce the yolk with a toothpick before cooking. Never cook eggs without piercing their shells.

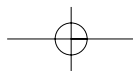

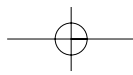

QUESTIONS AND ANSWERS (continued)

* Q : Why is standing time recommended after the cooking operation has been completed?

A : Standing time is very important.

With microwave cooking, the heat is in the food, not in the oven. Many foods build up enough internal heat to allow the cooking process to continue, even after the food is removed from the oven. Standing time for joints of meat, large vegetables and cakes allows the inside to cook completely, without overcooking the outside.

* Q : What does "standing time" mean?

A : "Standing time" means that food should be removed from the oven and covered for additional time to allow it to finish cooking. This frees the oven for other cooking.

* Q : Why does my oven not always cook as fast as the microwave cooking guide says?

A : Check your cooking guide again, to make sure you've followed directions exactly ; and to see what might cause variations in cooking time. Cooking guide times and heat settings are suggestions, to help prevent over-cooking... the most common problem in getting used to a microwave oven.

Variations in the size, shape and weights and dimensions could require longer cooking time. Use your own judgement along with the cooking guide suggestions to check whether the food has been properly cooked just as you would do with a conventional cooker.

* Q : Will the microwave oven be damaged if it operates while empty?

A : Yes. Never run it empty.

* Q : Can I pop popcorn in my microwave oven? How do I get the best results?

A : Yes. Pop packaged microwave popcorn following manufactures guidelines or use the preset POPCORN pad. Do not use regular paper bags. Use the "listening test" by stopping the oven as soon as the popping slows to a "pop" every 1 or 2 seconds. Do not repop unpopped kernels. Do not pop popcorn in glass cookware.

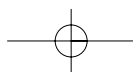

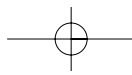

WARRANTY

This Bonn Commercial Microwave Oven is supplied with a 12 month from the date of purchase. This warranty covers the cost of parts for 12 months from the date of purchase. It also covers the cost of labour for the first 12 months from date of purchase. The conditions of this warranty are subject to the terms and conditions set out below. Any service claimed under warranty must be done with full proof of purchase including serial number. Failure to do so will incur service costs to the purchaser.

TERMS AND CONDITIONS

1. PURCHASER'S STATUTORY RIGHT

The warranty terms set out below do not exclude any conditions or warranties which may be mandatory implied by law, and your attention is drawn to the provisions of the Trade Practices Act 1974 and State Legislation which confers certain rights on consumers.

2. WARRANTY

(A) 12 MONTH PARTS AND 12 MONTH LABOUR WARRANTY

Bonn Appliances warrants to the original purchaser of this commercial microwave oven that for a period of 12 months from date of purchase, any component found by Bonn Appliances to be defective will be replaced by Bonn Appliances without charge for parts. For a period of 12 months from the date of purchase, such components will be replaced without charge for labour.

This warranty is given on the condition that all service is to be performed by Bonn Appliances or by a service agent authorised by Bonn Appliances to service commercial microwave oven.

If the oven is installed within a reasonable distance from an authorised service agent Bonn Appliances will, at its cost, effect warranty service on-site. Bonn Appliances shall have the exclusive right to determine what is a reasonable distance in each case. If the oven is installed outside of this area the customer shall bear the cost of sending the product to the agent or the agent's travelling cost to the purchaser's premises.

(B) EXCLUSIONS

The warranty set forth in paragraph 2(A) should not apply:

- (i) To any defect or failure which, upon inspection by Bonn Appliances or its authorised service agent, is attributable to accident, misuse, abuse, negligence, alteration, non-observance of operating instructions or local regulations, improper installation, inadequate or faulty power supply, damage during transit and/or delivery, fire, flood, riot or any act of God, normal wear and tear, in particular to but not restricted to Stirrer Covers, Ceramic Bases, Lamps, Door Assemblies and Cavities.
- (ii) If the equipment has been serviced by a person not authorised by Bonn Appliances or with parts not approved by Bonn Appliances.
- (iii) If Serial Number plate is removed or defaced.
- (iv) To any costs related to operator instructions, correction of program errors, interior or exterior finishes attributable to a manufacturing fault, routine maintenance or cleaning.
- (v) To loose accessories.
- (vi) If the equipment is repossessed under any financing agreement.
- (vii) If the equipment is used outside Australia without the prior written approval of Bonn Appliances.

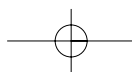

TERMS AND CONDITIONS (CONTINUED)

(B) EXCLUSIONS

The warranty set forth in paragraph 2(A) should not apply:

- (i) To any defect or failure which, upon inspection by Bonn Appliances or its authorised service agent, is attributable to accident, misuse, abuse, negligence, alteration, non-observance of operating instructions or local regulations, improper installation, inadequate or faulty power supply, damage during transit and/or delivery, fire, flood, riot or any act of God, normal wear and tear, in particular to but not restricted to Stirrer Covers, Ceramic Bases, Lamps, Door Assemblies and Cavities.
- (ii) If the equipment has been serviced by a person not authorised by Bonn Appliances or with parts not approved by Bonn Appliances.
- (iii) If Serial Number plate is removed or defaced.
- (iv) To any costs related to operator instructions, correction of program errors, interior or exterior finishes attributable to a manufacturing fault, routine maintenance or cleaning.
- (v) To loose accessories.
- (vi) If the equipment is repossessed under any financing agreement.
- (vii) If the equipment is used outside Australia without the prior written approval of Bonn Appliances.

3. All claims under this warranty should be directed to Bonn Appliances on Ph. 0500 844 333 Australia wide.

4. Subject to the purchaser's statutory rights referred to in Clause 1, Bonn Appliances reserves the right to charge for any service not covered by the company warranty.

Important

- Read the operating manual before operating your microwave oven.
Familiarize your staff with oven operation before placing in service.
- Should you require service under warranty, please consult the instruction book before you call for service as service call for non-equipment failure or instruction on use may result in a service labour charge for your account.

CONTACT

For additional information and details of your nearest service agent authorized by Bonn Appliances contact:

Bonn Appliances
4/40 Rivergate Place
Murarie
Qld 4172

Ph. 07-3390 4185
Fax. 07-3393 9508

www.bonnappliances.com

Bonn

COMMERCIAL MICROWAVE OVEN