

# Bonn

## MICROWAVE OVEN

COMMERCIAL MICROWAVE OVEN

CM-1021T

# SERVICE *Manual*

**MICROWAVE OVEN**

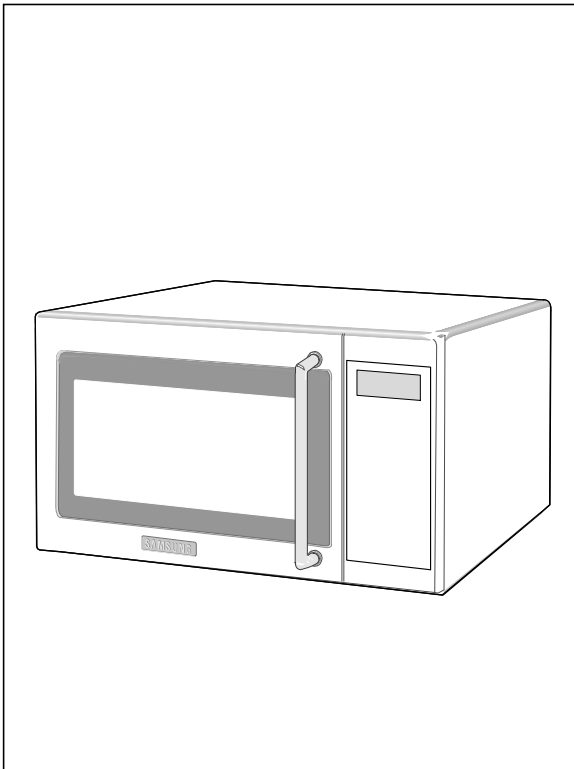

**TRANSIMPEX**

**CONTENTS**

1. Precaution
2. Specifications
3. Operating Instructions
4. Disassembly and Reassembly
5. Alignment and Adjustments
6. Troubleshooting
7. Exploded Views and Parts List
8. PCB Diagrams
9. Schematic Diagrams

## **PRECAUTIONS TO BE OBSERVED BEFORE AND DURING SERVICING TO AVOID POSSIBLE EXPOSURE TO EXCESSIVE MICROWAVE ENERGY**

- (a) Do not operate or allow the oven to be operated with the door open.
  - (b) Make the following safety checks on all ovens to be serviced before activating the magnetron or other microwave source, and make repairs as necessary:
    - (1) Interlock operation,
    - (2) proper door closing,
    - (3) seal and sealing surfaces (arcing, wear, and other damage),
    - (4) damage to or loosening of hinges and latches,
    - (5) evidence of dropping or abuse.
  - (c) Before turning on microwave power for any service test or inspection within the microwave generating compartments, check the magnetron, wave guide or transmission line, and cavity for proper alignment, integrity, and connections.
  - (d) Any defective or misadjusted components in the interlock, monitor, door seal, and microwave generation and transmission systems shall be repaired, replaced, or adjusted by procedures described in this manual before the oven is released to the owner.
  - (e) A Microwave leakage check to verify compliance with the Federal performance standard should be performed on each oven prior to release to the owner.
-

---

# 1. Precaution

---

Follow these special safety precautions. Although the microwave oven is completely safe during ordinary use, repair work can be extremely hazardous due to possible exposure to microwave radiation, as well as potentially lethal high voltages and currents.

## 1-1 Safety precautions (⚠)

---

1. All repairs should be done in accordance with the procedures described in this manual. This product complies with Federal Performance Standard 21 CFR Subchapter J(DHHS).
2. Microwave emission check should be performed to prior to servicing if the oven is operative.
3. If the oven operates with the door open :  
Instruct the user not to operate the oven and contact the manufacturer and the center for devices and radiological health immediately.
4. Notify the Central Service Center if the microwave leakage exceeds 5 mW/cm<sup>2</sup>
5. Check all grounds.
6. Do not power the MWO from a "2-prong" AC cord. Be sure that all of the built-in protective devices are replaced. Restore any missing protective shields.
7. When reinstalling the chassis and its assemblies, be sure to restore all protective devices, including: nonmetallic control knobs and compartment covers.
8. Make sure that there are no cabinet openings through which people particularly children might insert objects and contact dangerous voltages. Examples: Lamp hole, ventilation slots.
9. Inform the manufacturer of any oven found to have emission in excess of 5 mW/cm<sup>2</sup> ,  
Make repairs to bring the unit into compliance at no cost to owner and try to determine cause.  
Instruct owner not to use oven until it has been brought into compliance.
10. Service technicians should remove their watches while repairing an MWO.
11. To avoid any possible radiation hazard, replace parts in accordance with the wiring diagram. Also, use only the exact replacements for the following parts:  
Primary and secondary interlock switches, interlock monitor switch.
12. If the fuse is blown by the Interlock Monitor Switch: Replace all of the following at the same time: Primary, door sensing switch and power relay, as well as the Interlock Monitor Switch. The correct adjustment of these switches is described elsewhere in this manual. Make sure that the fuse has the correct rating for the particular model being repaired.
13. Design Alteration Warning:  
Use exact replacement parts only, i.e., only those that are specified in the drawings and parts lists of this manual. This is especially important for the Interlock switches, described above. Never alter or add to the mechanical or electrical design of the MWO. Any design changes or additions will void the manufacturer's warranty.10.Always unplug the unit's AC power cord from the AC power source before attempting to remove or reinstall any component or assembly.
14. Never defeat any of the B+ voltage interlocks. Do not apply AC power to the unit (or any of its assemblies) unless all solid-state heat sinks are correctly installed.
15. Some semiconductor ("solid state") devices are easily damaged by static electricity. Such components are called Electrostatically Sensitive Devices (ESDs). Examples include integrated circuits and field-effect transistors.  
Immediately before handling any semiconductor components or assemblies, drain the electrostatic charge from your body by touching a known earth ground.
16. Always connect a test instrument's ground lead to the instrument chassis ground *before* connecting the positive lead; always remove the instrument's ground lead last.

### CENTRAL SERVICE CENTER

10. Service technicians should remove their watches while repairing an MWO.

## 1-2 Special Servicing Precautions (Continued)

17. When checking the continuity of the switches or transformer, always make sure that the power is OFF, and one of the lead wires is disconnected.
18. Components that are critical for safety are indicated in the circuit diagram by shading, ⚠ or ⚡.
19. Use replacement components that have the same ratings, especially for flame resistance and dielectric strength specifications. A replacement part that does not have the same safety characteristics as the original might create shock, fire or other hazards.

## 1-3 Special High Voltage Precautions

1. High Voltage Warning  
Do not attempt to measure any of the high voltages this includes the filament voltage of the magnetron. High voltage is present during any cook cycle.  
Before touching any components or wiring, always unplug the oven and discharge the high voltage capacitor (See Figure 1-1)
2. The high-voltage capacitor remains charged about 30 seconds after disconnection. Short the negative terminal of the high-voltage capacitor to the oven chassis. (Use a screwdriver.)
3. High voltage is maintained within specified limits by close-tolerance, safety-related components and adjustments. If the high voltage exceeds the specified limits, check each of the special components.

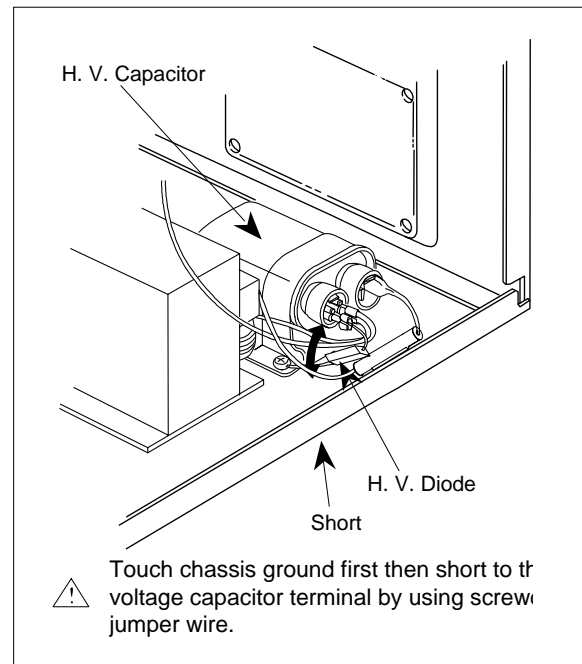

Fig. 1-1 Discharging High Voltage Capacitor

### PRECAUTION

There exists HIGH VOLTAGE ELECTRICITY with high current capabilities in the circuits of the HIGH VOLTAGE TRANSFORMER secondary and filament terminals. It is extremely dangerous to work on or near these circuits with the oven energized.  
DO NOT measure the voltage in the high voltage circuit including filament voltage of magnetron.

### PRECAUTION

Never touch any circuit wiring with your hand nor with uninsulated tool during operation.

### PRECAUTION

Servicemen should remove their watches whenever working close to or replacing the magnetron.

---

## 2. Specifications

---

### 2-1 Table of Specifications

---

TIMER	30 MINUTES
POWER SOURCE	240V 50Hz, AC
POWER CONSUMPTION	MICROWAVE : 1,450W
OUTPUT POWER	1000W (IEC-705 TEST PROCEDURE)
OPERATING FREQUENCY	2,450MHz
MAGNETRON	OM75PH(31)ESS
COOLING METHOD	COOLING FAN MOTOR
OUTSIDE DIMENSIONS	517(W) x 297(H) x 412(D)

---

## 3. Operating Instructions

---

### 3-1 Control Panel

---

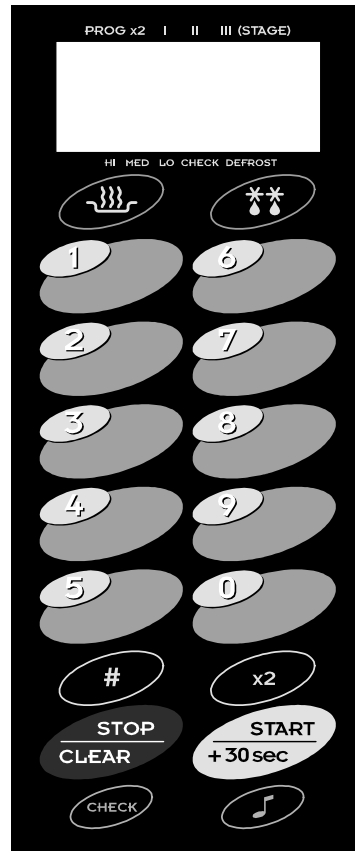

### 3-2 Features & External Views

---

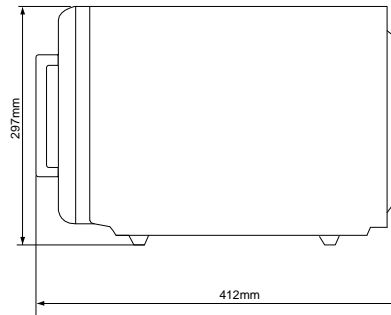
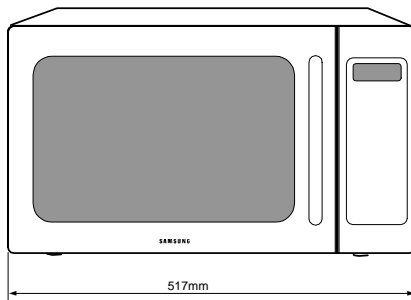
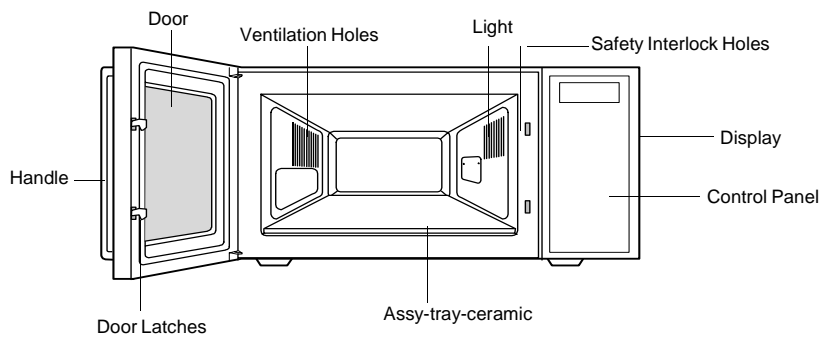

---

## 4. Disassembly and Reassembly

---

### 4-1 Replacement of Magnetron, Motor Assembly and Lamp

---

Remove the magnetron including the shield case, permanent magnet, choke coils and capacitors (all of which are contained in one assembly).

1. Disconnect all lead wires from the magnetron and lamp.
2. Remove a screw securing the magnetron supporter.
3. Remove the magnetron supporter.
4. Remove the air cover.
5. Remove screws securing the magnetron to the wave guide.
6. Take out the magnetron very carefully.
7. Remove screws from the back panel.
8. Take out the fan motor.
9. Remove the oven lamp by rotating to pull out from hole of air cover.

NOTE1: When removing the magnetron, make sure that its antenna does not hit any adjacent parts, or it may be damaged.

NOTE2: When replacing the magnetron, be sure to remount the magnetron gasket in the correct position and make sure the gasket is in good

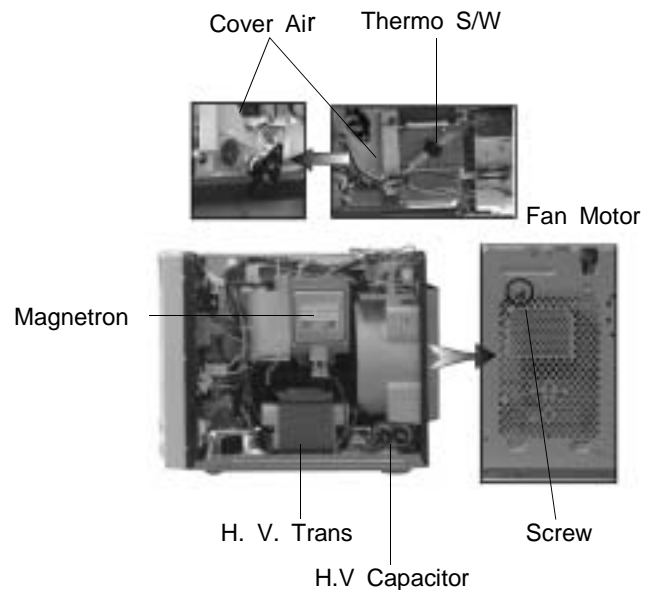

### 4-2 Replacement of High Voltage Transformer

---

1. Discharge the high voltage capacitor.
2. Disconnect all the leads.
3. Remove the mounting bolts.
4. Reconnect the leads correctly and firmly.

#### PRECAUTION

Servicemen should remove their watches whenever working close to or replacing the magnetron.

#### PRECAUTION

There exists HIGH VOLTAGE ELECTRICITY with high current capabilities in the circuits of the HIGH VOLTAGE TRANSFORMER secondary and filament terminals. It is extremely dangerous to work on or near these circuits with the oven energized.  
DO NOT measure the voltage in the high voltage circuit including filament voltage of magnetron.

---

## 4-3 Replacement of Door Assembly

---

### 4-3-1 Removal of Door Assembly

Remove hex bolts securing the upper hinge and lower hinge. Then remove the door assembly.

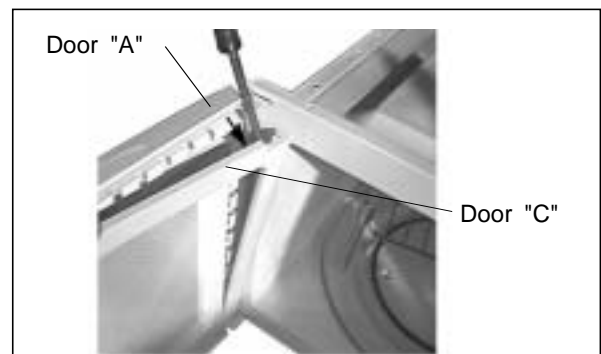

### 4-3-2 Removal of Door "C"

Insert flat screwdriver into the gap between Door "E" and Door "C" to remove Door "C". Be careful when handling Door "C" because it is fragile.



### 4-3-3 Removal of Door "E"

Following the procedure as shown in the figure, insert and bend a thin metal plate between Door "E" and Door "A" until you hear the 'tick' sound.

1. Insertion depth of the thin metal plate should be 0.5mm or less.

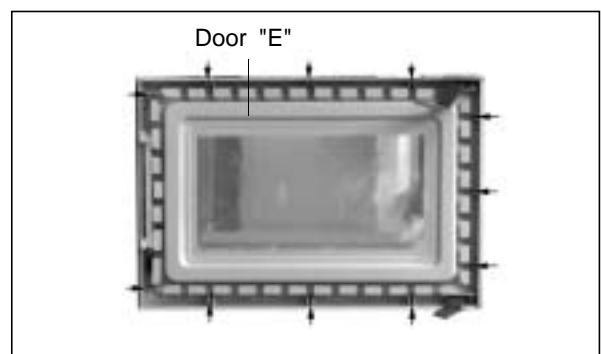

### 4-3-4 Removal of Key Door & Spring

Remove pin hinge from Door "E"  
Detach spring from Door "E" and key door.

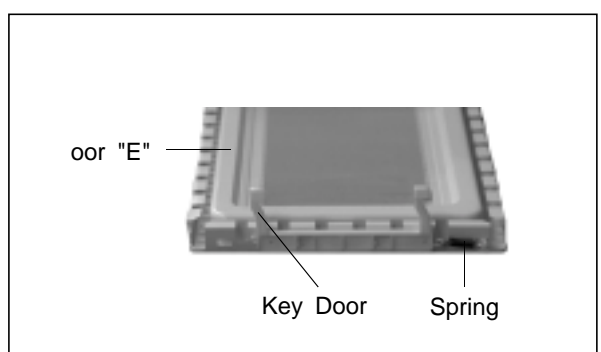

---

## 4-3-4 Reassembly Test

---

After replacement of the defective component parts of the door, reassemble it and follow the instructions below for proper installation and adjustment so as to prevent an excessive microwave leakage.

1. When mounting the door to the oven, be sure to adjust the door parallel to the bottom line of the oven face plate by moving the upper hinge and lower hinge in the direction necessary for proper alignment.
2. Adjust so that the door has no play between the inner door surface and oven front surface. If the door assembly is not mounted properly, microwave energy may leak from the space between the door and oven.
3. Do the microwave leakage test.

## 4-4 Replacement of Fuse

---

1. Disconnect the oven from the power source.
2. When 15A fuse blows out by the operation of interlock monitor switch failure, replace the primary interlock switch, door sensing switch, monitor switch and power relay.
3. When the above three switches operate properly, check if any other part such as the control circuit board, blower motor or high voltage transformer is defective.

## 4-5 Replacement of Drive Motor

---

1. Take out the glass tray, guide roller and coupler from cavity.
2. Turn the oven upside down to replace the drive motor.
3. Remove a screw securing the drive motor cover.
4. Disconnect all the lead wires from the drive motor.
5. Remove screws securing the drive motor to the cavity.
6. Remove the drive motor.
7. When replacing the drive motor, be sure to remount it in the correct position.
8. Connect all the leads to the drive motor.
9. Screw the drive motor cover to the base plate with a screw driver.
10. Remount the coupler in the correct position.

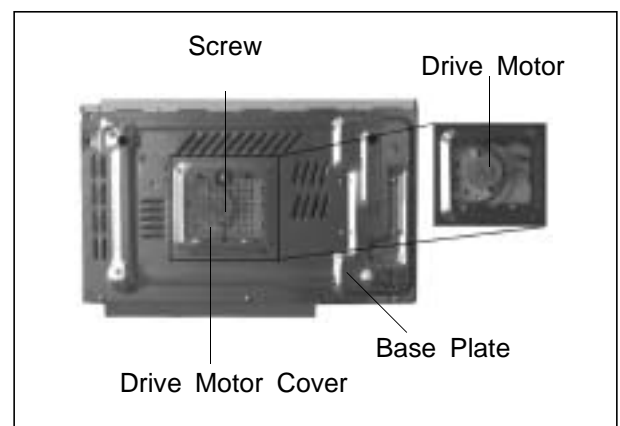

---

## 4-6 Replacement of Control Circuit Board

---

### 4-6-1 Removal of Ass'y Control Box

1. Be sure to ground any static electric charge in your body and never touch the touch control circuitry.
2. Disconnect the connectors from the control circuit board.
3. Remove screws securing the control box assembly.
4. Remove the screw securing the ground tail of the keyboard.

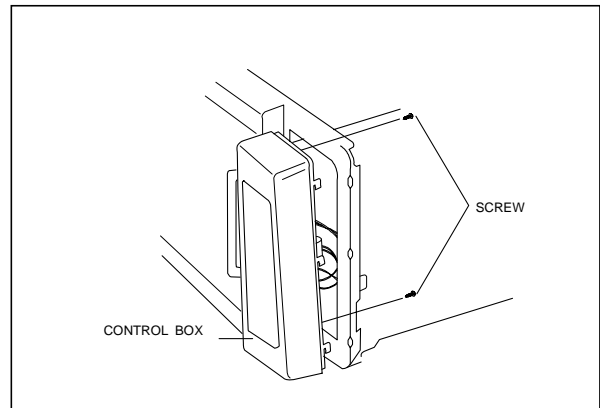

### 4-6-2 Removal of Ass'y P.C.B

1. Pull the lever end of the plastic fastener and remove the Flexible Printed Circuit(FPC) of membrane panel.
2. Remove screws securing the control circuit board.
3. Lift up the control circuit board from the Ass'y control box.
4. When reconnecting the FPC connector, make sure that the holes on the connector are properly engaged with the hooks on the Plastic Fastener.

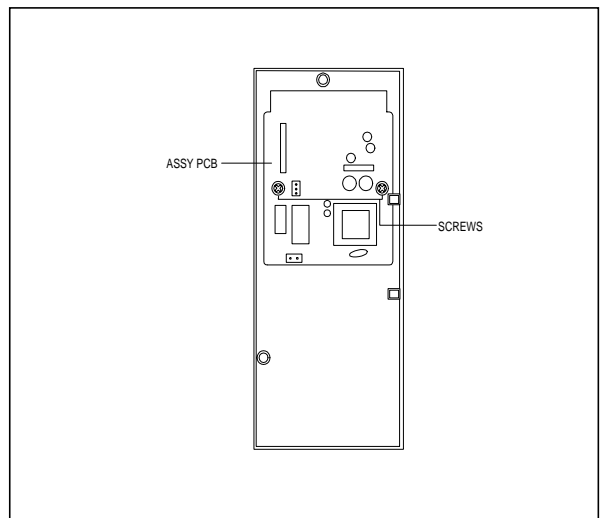

## 5. Alignment and Adjustments

### PRECAUTION

1. High voltage is present at the high voltage terminals during any cook cycle.
2. It is neither necessary nor advisable to attempt measurement of the high voltage.
3. Before touching any oven components or wiring, always unplug the oven from its power source and discharge the high voltage capacitor.

### 5-1 High Voltage Transformer

1. Remove connectors from the transformer terminals and check continuity.
2. Normal resistance readings are as follows:

Secondary	Approx.90.Ω.
Filament	Approx.0.Ω.
Primary	Approx.1.2.Ω

(Room temperature = 20°C)

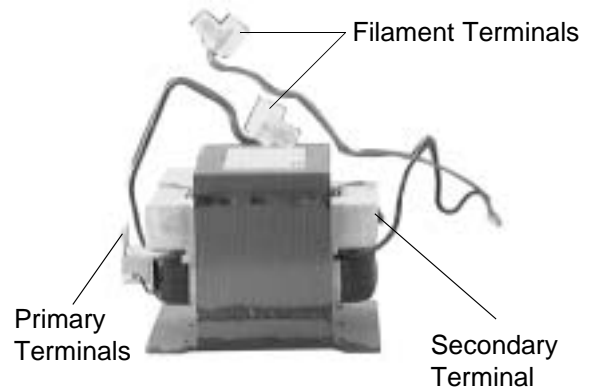

### 5-2 Low Voltage Transformer

1. The low voltage transformer is located on the control circuit board.
2. Remove the low voltage transformer from the PCB Ass'y and check continuity.
3. Normal resistor reading is shown in the table.

Terminals	Resistance
1~2(Input)	1,713.Ω.
4~5(Output 2.2V)	4.32.Ω..
7~8(Output17.5V)	39.1.Ω.

### 5-3 Magnetron

1. Continuity checks can indicate only an open filament or a shorted magnetron. To diagnose an open filament or shorted magnetron :
2. Isolate the magnetron from the circuit by disconnecting its leads.
3. A continuity check across the magnetron filament terminals should indicate one ohm or less.
4. A continuity check between each filament terminal and magnetron case should read open.

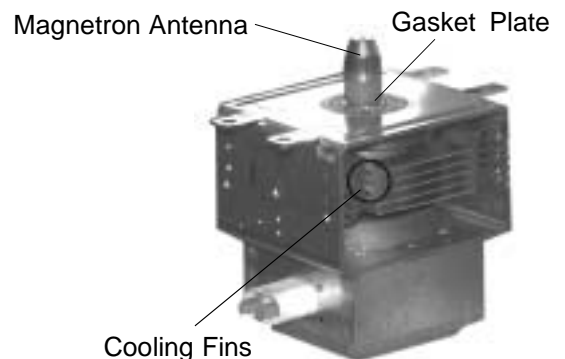

## 5-4 High Voltage Capacitor

1. Check continuity of the capacitor with the meter set at the highest resistance scale.
2. Once the capacitor is charged, a normal capacitor shows continuity for a short time, and then indicates 9M.
3. A shorted capacitor will show continuous continuity.
4. An open capacitor will show constant 9M.
5. Resistance between each terminal and chassis should read infinite.

## 5-5 High Voltage Diode

1. Isolate the diode from the circuit by disconnecting its leads.
2. With the ohm-meter set at the highest resistance scale, measure across the diode terminals. Reverse the meter leads and read the resistance. A meter with 6V, 9V or higher voltage batteries should be used to check the front-to back resistance of the diode (otherwise an infinite resistance may be read in both directions). The resistance of a normal diode will be infinite in one direction and several hundred Kin the other direction.

## 5-6 Main Relay and Power Control Relay

1. The relays are located on the PCB Ass'y. Isolate them from the main circuit by disconnecting the leads.
2. Operate the microwave oven with a water load in the oven. Set the power level set to high.
3. Check continuity between terminals of the relays after the start pad is pressed.

## 5-7 Adjustment of Primary Switch, Door Sensing Switch and Monitor Switch

### Precaution

For continued protection against radiation hazard, replace parts in accordance with the wiring diagram and be sure to use the correct part number for the following switches: Primary and secondary interlock switches, and the interlock monitor switch (replace all together). Then follow the adjustment procedures below. After repair and adjustment, be sure to check the continuity of all interlock switches and the interlock monitor switch.

1. When mounting Primary switch and Interlock Monitor switch to Latch Body, consult the figure.
2. No specific adjustment during installation of Primary switch and Monitor switch to the latch body is necessary.
3. When mounting the Latch Body to the oven assembly, adjust the Latch Body by moving it so that the oven door will not have any play in it. Check for play in the door by pulling the door assembly. Make sure that the latch keys move smoothly after adjustment is completed. Completely tighten the screws holding the Latch Body to the oven assembly.
4. Reconnect to Monitor switch and check the continuity of the monitor circuit and all latch switches again by following the components test procedures.
5. Confirm that the gap between the switch housing and the switch actuator is no more than 0.5mm when door is closed.
6. **Interlock Switch Replacement** - When replacing faulty switches, be sure switch mounting tabs are not bent, broken or otherwise deficient in their ability to secure the switches in place.

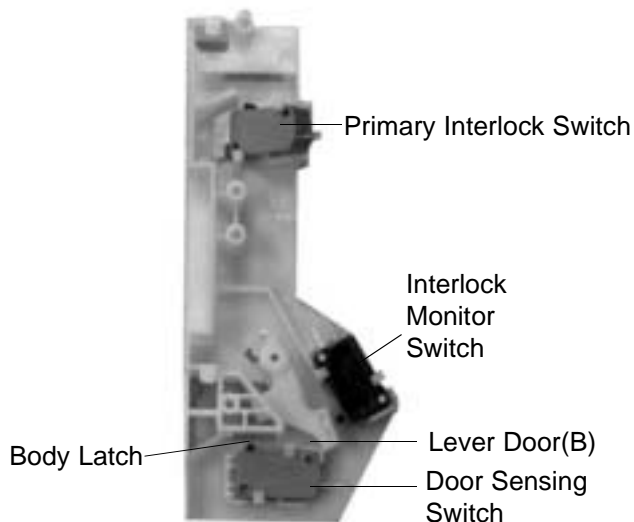

	Door Open	Door Closed
Primary switch	$\infty$	0
Monitor switch (COM-NC)	0	$\infty$
Monitor switch (COM-NO)	$\infty$	0
Door Sensing S/W	$\infty$	0

---

## 5-8 Output Power of Magnetron

---

### CAUTION

#### MICROWAVE RADIATION

PERSONNEL SHOULD NOT ALLOW EXPOSURE TO MICROWAVE RADIATION FROM MICROWAVE GENERATOR OR OTHER PARTS CONDUCTING MICROWAVE ENERGY.

The output power of the magnetron can be measured by performing a water temperature rise test.

Equipment needed :

\* Two 1-liter cylindrical borosilicate glass vessel (Outside diameter 190 mm)

\* One glass thermometer with mercury column

NOTE: Check line voltage under load. Low voltage will lower the magnetron output. Make all temperature and time tests with accurate equipment.

1. Fill the one liter glass vessel with water.
2. Stir water in glass vessel with thermometer, and record glass vessel's temperature ("T1", 10±1°C).
3. After moving the water into another glass vessel, place it in the center of the cooking tray. Set the oven to high power and operate for 45 seconds exactly. ( 3 seconds included as a holding time of magnetron oscillation:)
4. When heating is finished, stir the water again with the thermometer and measure the temperature ("T2").
5. Subtract T1 from T2. This will give you the water temperature rise. ( $\Delta T$ )
6. The output power is obtained by the following formula;

$$\text{Output Power} = \frac{4.187 \times 1000 \times \Delta T + 0.55 \times MC \times (T_2 - T_0)}{42}$$

45 : Heating Time (sec)

4.187 : Coefficient for Water

1000 : Water (cc)

$\Delta T$  : Temperature Rise (T2-T1)

MC : Cylindrical borosilicate glass weight

T<sub>0</sub> : Room temperature

7. Normal temperature rise for this model is 9°C to 11°C at 'HIGH'.

NOTE 1: Variations or errors in the test procedure will cause a variance in the temperature rise.

Additional power test should be made if temperature rise is marginal.

NOTE 2: Output power in watts is computed by multiplying the temperature rise (step E) by a factor of 91 times the of centigrade temperature.

---

## 5-9 Procedure for Measurement of Microwave Energy Leakage

---

- 1) Pour  $275 \pm 15$ cc of  $20 \pm 5^\circ\text{C}$  ( $68 \pm 9^\circ\text{F}$ ) water in a beaker which is graduated to 600cc, and place the beaker in the center of the oven.
- 2) Start to operate the oven and measure the leakage by using a microwave energy survey meter.
- 3) Set survey meter with dual ranges to 2,450MHz.
- 4) When measuring the leakage, always use the 2 inch spacer cone with the probe. Hold the probe perpendicular to the cabinet door. Place the spacer cone of the probe on the door and/or cabinet door seam and move along the seam, the door viewing window and the exhaust openings moving the probe in a clockwise direction at a rate of 1 inch/sec. If the leakage testing of the cabinet door seam is taken near a corner of the door, keep the probe perpendicular to the areas making sure that the probe end at the base of the cone does not get closer than 5cm to any metal. If it gets closer than 5cm, erroneous readings may result.
- 5) Measured leakage must be less than  $4\text{mW}/\text{cm}^2$ , after repair or adjustment.

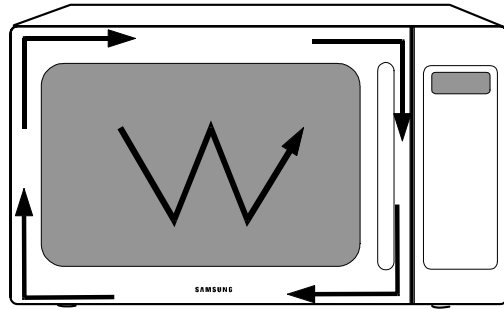

Maximum allowable leakage is  $5\text{mW}/\text{cm}^2$ .  
 $4\text{mW}/\text{cm}^2$  is used to allow for measurement and meter accuracy

---

## 5-10 Check for Microwave Leakage

---

1. Remove the outer panel.
2. Pour  $275 \pm 15$ cc of  $20 \pm 5^\circ\text{C}$  ( $68 \pm 9^\circ\text{F}$ ) water in a beaker which is graduated to 600cc, and place the beaker in the center of the oven.
3. Start the oven at the highest power level.
4. Set survey meter dual ranges to 2,450MHz.
5. Using the survey meter and spacer cone as described above, measure around the opening of magnetron, the surface of the air guide and the surface of the wave guide as shown in the following photo. (but avoid the high voltage components.) The reading should be less than  $4\text{mW}/\text{cm}^2$ .



---

## 5-11 Note on Measurement

---

- 1) Do not exceed the limited scale.
- 2) The test probe must be held on the grip of the handle, otherwise a false reading may result when the operator's hand is between the handle and the probe.
- 3) When high leakage is suspected, do not move the probe horizontally along the oven surface; this may cause damage to the probe.
- 4) Follow the recommendation of the manufacturer of the microwave energy survey meter.

---

## 5-12 Leakage Measuring Procedure

---

### 5-12-1 Record keeping and notification after measurement

- 1) After adjustment and repair of a radiation preventing device, make a repair record for the measured values, and keep the data.
- 2) If the radiation leakage is more than  $4\text{mW}/\text{cm}^2$  after determining that all parts are in good condition, functioning properly and the identical parts are replaced as listed in this manual notify that fact to ;

### CENTRAL SERVICE CENTER

- 5-12-2 At least once a year have the microwave energy survey meter checked for accuracy by its manufacturer.

## 6. Troubleshooting

### PRECAUTION

1. CHECK GROUNDING BEFORE CHECKING FOR TROUBLE.
2. BE CAREFUL OF THE HIGH VOLTAGE CIRCUIT.
3. DISCHARGE THE HIGH VOLTAGE CAPACITOR.
4. WHEN CHECKING THE CONTINUITY OF THE SWITCHES OR TRANSFORMER, DISCONNECT ONE LEAD WIRE FROM THESE PARTS AND THEN CHECK CONTINUITY WITHOUT THE POWER SOURCE ON. TO DO OTHERWISE MAY RESULT IN A FALSE READING OR DAMAGE TO YOUR METER.
5. DO NOT TOUCH ANY PART OF THE CIRCUIT OR THE CONTROL CIRCUIT BOARD, SINCE STATIC DISCHARGE MAY DAMAGE IT.  
ALWAYS TOUCH GROUND WHILE WORKING ON IT TO DISCHARGE ANY STATIC CHARGE BUILT UP.

### 6-1 Electrical Malfunction

SYMPTOM	CAUSE	CORRECTIONS
Oven is dead. Fuse is OK. No display and no operation at all.	<ol style="list-style-type: none"> <li>1. Open or loose lead wire harness</li> <li>2. Open thermal cutout (Magnetron)</li> <li>3. Open low voltage transformer</li> <li>4. Defective Ass'y PCB</li> </ol>	<p>Check fan motor when thermal cutout is defective.</p> <p>Check Ass'y PCB when LVT is defective.</p>
No display and no operation at all. Fuse is blown.	<ol style="list-style-type: none"> <li>1. Shorted lead wire harness</li> <li>2. Defective primary latch switch (NOTE 1)</li> <li>3. Defective monitor switch (NOTE1)</li> <li>4. Shorted HVCapacitor</li> <li>5. Shorted HVTransformer (NOTE2)</li> </ol> <p>NOTE 1: All of these switches must be replaced at the same time. (refer to adjustment instructions) Check continuity of power relay contacts and if it has continuity, replace power relay also.</p> <p>NOTE 2: When HVTransformer is replaced, check diode and magnetron also.</p>	<p>Check adjustment of primary, interlock monitor, power relay, door sensing switch.</p>
Oven does not accept key input (Program)	<ol style="list-style-type: none"> <li>1. Key input is not in-Sequence</li> <li>2. Open or loose connection of membrane key pad to Ass'y PCB</li> <li>3. Shorted or open membrane panel</li> <li>4. Defective Ass'y PCB</li> </ol>	<p>Refer to operation procedure.</p> <p>Replace PCB main.</p>
Timer starts countdown but no microwave oscillation. (No heat while oven lamp and fan motor turn on.)	<ol style="list-style-type: none"> <li>1. Off-alignment of latch switches</li> <li>2. Open or loose connection of high voltage circuit especially magnetron filament circuit</li> </ol> <p>NOTE: Large contact resistance will bring lower magnetron filament voltage and cause magnetron to lower output and/or intermittent oscillation.</p> <ol style="list-style-type: none"> <li>3. Defective high voltage components H.V.Transformers H.V. Capacitor H.V.Diode, H.V.Fuse Magnetron</li> <li>4. Open or loose wiring of power relay</li> <li>5. Defective primary latch switch</li> <li>6. Defective power relay or Ass'y PCB</li> </ol>	<p>Adjust door and latch switches.</p> <p>Check high voltage component according to component test procedure and replace if it is defective.</p> <p>Replace PCB main.</p>

## 6-1 Electrical Malfunction(continued)

SYMPTOM	CAUSE	CORRECTIONS
Oven lamp and fan motor turn on	<ol style="list-style-type: none"> <li>Misadjustment or loose wiring of primary latch switch</li> <li>Defective primary latch switch</li> </ol>	Adjust door and latch switches.
Oven can program but timer does not start.	<ol style="list-style-type: none"> <li>Open or loose wiring of secondary interlock switch</li> <li>Off-alignment of primary interlock</li> <li>Defective secondary interlock S/W</li> </ol>	Adjust door and interlock switches.
Microwave output is low; Oven takes longer time to cook food.	<ol style="list-style-type: none"> <li>Decrease in power source voltage.</li> <li>Open or loose wiring of magnetron filament circuit. (Intermittent oscillation))</li> <li>Aging of magnetron</li> </ol>	Consult electrician.
Fan motor turns on when plugged in	Loose wiring of door sensing switch	Check wire of door sensing switch.
Oven does not operate and return to the plugged in mode.	Defective Ass'y PCB	Replace PCB main.
Loud buzzing noise can be heard.	<ol style="list-style-type: none"> <li>Loose fan and fan motor</li> <li>Loose screws on H.V. Transformer</li> <li>Shorted H.V.Diode</li> </ol>	Tighten screws of fan motor. Tighten screws of H.V. Transformer. Replace H.V.Diode.
Turntable motor does not rotate.	<ol style="list-style-type: none"> <li>Open or loose wiring of turntable motor.</li> <li>Defective turntable motor.</li> </ol>	Replace turntable motor.
Oven stops operation during cooking	<ol style="list-style-type: none"> <li>Open or loose wiring of primary interlock switch</li> <li>Operation of thermal cutout(Magnetron)</li> </ol>	Adjust door and latch switches.
Sparks	<ol style="list-style-type: none"> <li>Metallic ware or cooking dishes touching on the oven wall.</li> <li>Ceramic ware trimmed with gold or silver powder also causes sparks.</li> </ol>	Inform the customer. Do not use any type of cookware with metallic trimming.
Uneven cooking	Uneven intensity of microwave due to its characteristics.	Wrap thinner parts of the food with aluminum foil. Use plastic wrap or cover with a lid. Stir once or twice while cooking foods such as soup, cocoa, or milk.
Noise from the turntable motor when it starts to operate.	Noise may result from the motor.	Replace turntable motor.



## 7-2 Main Parts List

No.	Code No.	Description	Specification	Q'ty	Remark
MB01	DE93-20020D	ASSY BODY LATCH	M959/XSA,-,-,-,-	1	
MB02	3405-000175	SWITCH-MICRO	250V,15A,200gf,SPST-NO	1	
MB03	3405-000178	SWITCH-MICRO	250V,15A,200gf,SPST-NO	2	
MB04	DE66-90054B	LEVER-SWITCH	NYLON#66(2021SW),40G,M959/XSA,	1	
MB05	DE66-40021B	LATCH-BODY	NYLON#66(2021SW),40g,M959/XSA,	1	
MM01	DE70-00011G	PANEL-OUTER	C/STEEL,T0.6,W360,L1128,D/GRY,-,-	1	
MM03	DE39-00234A	WIRE HARNESS-A	CM1049,-,-,230V50Hz,-,-,-,TCO VI,AMFO	1	
MM05	DE96-00010A	ASSY NOISE FILTER	SN-3WED,250V10A,3W NO-INRUSH TC,-,-	1	
MM06	DE96-00108A	ASSY-MOTOR FAN	SMF-1049,230V50Hz,2500rpm,RE-G50,-	1	
MM06	DE31-10177C	MOTOR-FAN	SMF-1049EA,-,-,230V50Hz,15mm,-,2500rpm,-	1	
MM07	DE39-20042K	ASSY POWER CORD	KKP-550A,1.0MM,BLK	1	
MM08	OM75P(31)ERH	ASSY-MAGNETRON:OM75P		1	
MM09	DE71-60016A	COVER-AIR	PP,2,WHT,M945/M245,-,-,-,-,-	1	
MM10	4713-001046	LAMP-INCANDESCENT	240V,104mA,25W,ORG,-,-,25x62mm	1	
MM14	DE26-00051A	TRANS-H.V	SHV-E1049A,230V,50Hz,2255V/3.50V,-,-,-,-	1	
MM16	DE71-00163A	COVER-CEILING	-,T0.5,W122.2,L137.6,-,CM1049,NEW	1	
MM17	DE47-20173A	THERMOSTAT	90/60,-,-,-,-,-	1	
MM18	DE97-00191A	ASSY-TRAY CERAMIC	CM1049,T3.2,COMMERCIAL,-	1	
MM22	DE31-10173A	MOTOR-SYNCHRONOUS	M2HJ29A709,ST-16F,21V,34.9RPM,	1	
MM27	DE61-40066A	FOOT	PP,BLK,-,-,3RD-W,-	2	
MM28	DE80-10001G	BASE-PLATE	SGCC,T0.8,W345,L565,3RD,-	1	
MM29	2501-001014	C-OIL	1.050uF,2100V,BK,35X54X85,20mm	1	
MM30	DE61-50106A	BRACKET-HVC	SECC,T0.8,W31,L125.8,-,-,-	1	
MM31	DE91-70063A	ASSY-HVD	V2M6,PI9.0,0.05MT,-,-	1	
MM32	DE91-70061H	ASSY-H.V.FUSE	THV060T-0900-H,5KV0.90A,WHT LABEL	1	
MM46	DE97-00190A	ASSY-STIRRER	CM1049,ALS	1	
MM52	DE63-90035G	CUSHION-RUBBER	DFA20,T2,W190,L100,BLK,-,-,-	1	HVT
MM55	3601-000448	FUSE-CARTRIDGE	250V,10A,SLOW-BLOW,CERAMIC,6.35x31.8mm	1	
MM88	DE73-90027A	FERRITE-CORE	NI-ZN,T13.8,W21.0,L28.0,BNF-14	1	

## 7-3 Control & Door Parts List

No.	Code No.	Description	Specification	Q'ty	Remark
MC01	-	ASSY CONTROL-BOX	-,CM-1021,SEMI COMMERCIAL	1	S.N.A
MC02	DE34-00138A	SWITCH MEMBRANE	CM-1021T,-,-,PET,-,-,-,-,-,SEMI COMMERCIAL	1	
MC03	-	CONTROL-PANEL	ABS,-,CM1030M,-,-,-,-	1	S.N.A
MC06	DE67-40179A	WINDOW-DISPLAY	SAN,T2.0,-,-,SMOG,-,3RD-W S1,-	1	
MC07	RC-CM1020B-01	ASSY PCB PARTS:CM104		1	
MC13	DE94-00393C	ASSY CONTROL-SUB	CM-1021T,SEMI COMMERCIAL	1	
MC37	-	SASH-PANEL	STS,-,-,-,-,CM1030M,-	1	S.N.A
MD01	DE94-00267N	ASSY DOOR	CM-1021T,SEMI COMMERCIAL	1	
MD02	-	DOOR-A	CM1049,ABS(HR0370D),-,D-GRY/G3328,-,-,-	1	S.N.A
MD03	-	SCREEN-DOOR(B)	CM-1021T,TEMP GLASS,-,-,-,-,SEMI	1	S.N.A
MD04	DE92-50127H	ASSY DOOR-E	COATING,BLACK,T0.8,-,-,-,-	1	
MD05	DE02-00002B	FILM-DOOR	PC,TO.15,275,175,MW5574W,-,-,-,-,-	1	
MD06	DE64-40012A	DOOR-C	RESIN-PP(TB53),T2.0,CE945GF,BL	1	
MD07	DE61-70126A	SPRING-KEY	0.8,0,36,6,BLUING,-,-	1	
MD08	DE61-80002A	HINGE-UPPER	SCP1,T2.3,26,77,ZPC3,WHT,CE945	1	
MD09	DE61-80003A	HINGE-LOWER	SCP1,T2.3,26,77,ZPC3,WHT,CE945	1	
MD10	DE64-40264B	DOOR-KEY	NYLON#66(2021SW),40G,-,M959/XS	1	
MD11	DE94-00265M	ASSY DOOR-SUB	CM-1021T,-,SEMI-COMMERCIAL	1	
MD14	DE64-00076A	HANDLE	ZN DIECASTING,-,-,-,-,CK99FS,-,-	1	
MD18	-	HANDLE-COVER	PC,-,-,-,-,CK99FS,-,-,-,-	1	S.N.A
MD26	-	SASH-DOOR	STS,-,-,-,CK99FS,-,-,-,-	1	S.N.A

S.N.A : SERVICE NOT AVAILABLE

## 7-4 Standard Parts List

Code No.	Description	Specification	Q'ty	Remark
DE60-10012A	SCREW-TAP TITE	TH,+3,M4,L10,SWR10,ZPC2,TOOTH	1	N/F-EAR
DE60-10012A	SCREW-TAP TITE	TH,+3,M4,L10,SWR10,ZPC2,TOOTH	1	P/C-EAR
DE60-10012A	SCREW-TAP TITE	TH,+3,M4,L10,SWR10,ZPC2,TOOTH	1	PCB-EAR
DE60-10059A	SCREW-TAP TH	TH,M4,L8,SUS410,CR,-,-,-,-,-	2	C/CEILING
DE60-10080B	SCREW-WASHER	PH,PI5,L10,SWRCH18A,ZP2,2S,-,-	4	MGT
DE60-10080B	SCREW-WASHER	PH,PI5,L10,SWRCH18A,ZP2,2S,-,-	4	TNS-HV
DE60-10082H	SCREW-A	2S-4X12,TOOTHED,-,-,-,-,-,-,-,-	3	B-PLTE
DE60-10082H	SCREW-A	2S-4X12,TOOTHED,-,-,-,-,-,-,-,-	2	BD-LAT
DE60-10082H	SCREW-A	2S-4X12,TOOTHED,-,-,-,-,-,-,-,-	2	CN-BOX
DE60-10082H	SCREW-A	2S-4X12,TOOTHED,-,-,-,-,-,-,-,-	1	CV/AIR
DE60-10082H	SCREW-A	2S-4X12,TOOTHED,-,-,-,-,-,-,-,-	2	MO/FAN
DE60-10082H	SCREW-A	2S-4X12,TOOTHED,-,-,-,-,-,-,-,-	5	PN/OUT
DE60-10082H	SCREW-A	2S-4X12,TOOTHED,-,-,-,-,-,-,-,-	2	TCO
DE60-10098A	SCREW-ASSY TAP TITE	PH,TC,M4X8,SWRCH18A,ZPC2,GLD,W	2	M/DRV
DE60-10012A	SCREW-TAP TITE	TH,+3,M4,L10,SWR10,ZPC2,TOOTH	1	
DE60-10082H	SCREW-A	2S-4X12,TOOTHED,-,-,-,-,-,-,-,-	2	handle
DE60-10088A	SCREW-TAP PH	PH,M3,L8,FEFZY,PLAIN,-,-,-,-,-	2	

# 8. P.C.B Diagrams

## 8-1 P.C.B Diagrams

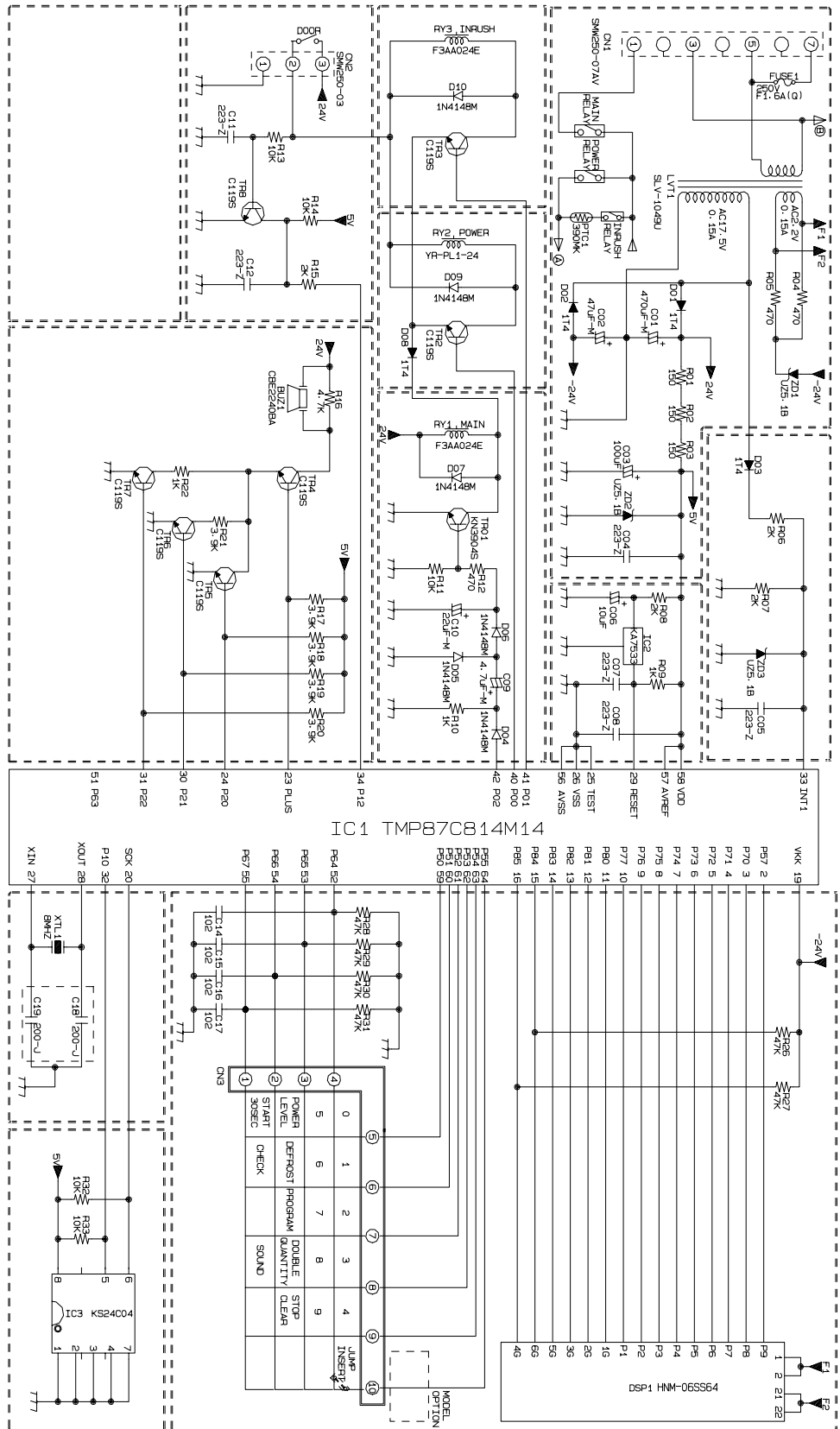

CM1049  
SCHEMATIC

## 8-2 P.C.B Parts List

Code No.	Description	Specification	Q'ty	Remark
3002-000198	BUZZER-PIEZO	80dB,-,-,4KHz,ST	1	BUZ1
3501-001155	RELAY-MINIATURE	24VDC,200MW,3000MA,1FORMA,10MS,10MS	1	RY1,3
3601-001126	FUSE-CARTRIDGE	250V,1.6A,FAST-ACTING,CERAMIC,5x20mm	1	FUS1
3708-001508	CONNECTOR-FPC/FC/PIC	10P,1.25mm,STRAIGHT,SN	1	CN3
DE07-00012A	VF DISPLAY	HNM-06SS64,CM1020L,67.2x.5.0x10,1/7.50,-,-	1	DSP1
DE47-40024A	HOLDER-FUSE	FH-51H,7.5A,-,-,-,-	1	FUS1
DE61-00095A	HOLDER-DIGITRON	NYLON#66,-,-,-,CM1020L,-	1	DSP1
DE92-00632A	ASSY PCB AUTO	230V50Hz,VFD,RC-CM1020B-01,CM1049	1	
0401-001083	DIODE-SWITCHING	MM4148,100V,150MA,LL-34,TP	6	D04~07,09,10
0402-001103	DIODE-RECTIFIER	1T4,400V,1A,TS-1,TP	4	D01,02,03,08
0403-001288	DIODE-ZENER	ZMM55C5V1,4.8-5.4V,500MW,LL-34,TP	3	ZD1,2,3
0501-000465	TR-SMALL SIGNAL	MMBT3904,NPN,350mW,SOT-23,TP,100-300	1	TR1
0504-000130	TR-DIGITAL	KSR1105TF,NPN,200MW,4.7K/10K,SOT-23,TP	8	TR2~8
1103-001163	IC-EEPROM	S524C80D41,512x8Bit,SOP,8P,150MIL,10mS,5V,10%,-	1	IC3
1202-000141	IC-VOLTAGE COMP.	7033,SOT-89,3P,-,SINGLE,0V,-,P	1	IC2
1404-001194	THERMISTOR-PTC	39ohm,20%,220/240V,270Vac,1.2A,-,TP	1	PTC1
2001-001077	R-CARBON(S)	150OHM,5%,1/2W,AA,TP,2.4X6.4MM	3	R01,02,03
2007-000033	R-CHIP	0OHM,5%,1/8W,DA,TP,3216	2	J01,11
2007-000300	R-CHIP	10KOHM,5%,1/10W,DA,TP,2012	5	R11,13,14,32,33
2007-000468	R-CHIP	1KOHM,5%,1/10W,DA,TP,2012	3	R09,10,22
2007-000671	R-CHIP	2KOHM,5%,1/10W,DA,TP,2012	4	R06,07,08,15
2007-000710	R-CHIP	3.9KOHM,5%,1/10W,DA,TP,2012	5	R17~21
2007-000872	R-CHIP	4.7KOHM,5%,1/10W,DA,TP,2012	1	R16
2007-000931	R-CHIP	470OHM,5%,1/10W,DA,TP,2012	3	R04,05,12
2007-000941	R-CHIP	47KOHM,5%,1/10W,DA,TP,2012	6	R26~31
2203-000444	C-CERAMIC,CHIP	1nF,10%,50V,X7R,TP,2012,-	4	C14~17
2203-000555	C-CERAMIC,CHIP	0.02nF,5%,50V,NP0,TP,2012	2	C18,19
2203-001608	C-CERAMIC,CHIP	22nF,+80-20%,50V,Y5V,TP,2012	6	C04,05,07,08,11,12
2401-000244	C-AL	100uF,20%,10V,GP,TP,6.3x7,5	1	C03
2401-000466	C-AL	10uF,20%,35V,GP,TP,5x7,5	1	C06
2401-000911	C-AL	22uF,20%,16V,GP,TP,5x7,5	1	C10
2401-001415	C-AL	470uF,20%,35V,GP,TP,10x20,5	1	C01
2401-001573	C-AL	47uF,20%,50V,GP,TP,6.3x11,2.5	1	C02
2401-002075	C-AL	4.7uF,20%,50V,GP,TP,5x11,5	1	C09
2801-003933	CRYSTAL-UNIT	8MHz,50ppm,28-AAA,12pF,70ohm,TP	1	XTL1
3501-001062	RELAY-POWER	24VDC,523.2mW,16A,1FormA,15mS,	1	RY2
3711-000881	CONNECTOR-HEADER	BOX,3P,1R,2.5mm,STRAIGHT,SN	1	CN2
3711-004200	CONNECTOR-HEADER	BOX,5P/7P,1R,2.5MM,STRAIGHT,SN	1	CN1
DE09-00108A	IC MICOM	TMP87PM14F,OTP-32K,QFP,8BIT-64PIN,-,-,-,-	1	IC1
DE26-00050A	TRANS-L.V	SLV-1049E,230V,50Hz,AC17.5V/2.2V,NO-FUSE,35*10,P	1	LVT1
DE39-60001A	WIRE-SO COPPER	PI0.6,SN,T,52MM,TAPING_WIRE,-,	11	J03~10,12~14
DE41-00150A	PCB-MAIN	RA-CM1020B-00,FR-1,-,-,197*329,-,-,CM1020B	1	
DE60-60012A	PIN-EYELET	ID2.1,OD2.5,L3.0,SN,BSP,T0.25,	2	

# 9. Schematic Diagrams

## 9-1 Schematic Diagrams

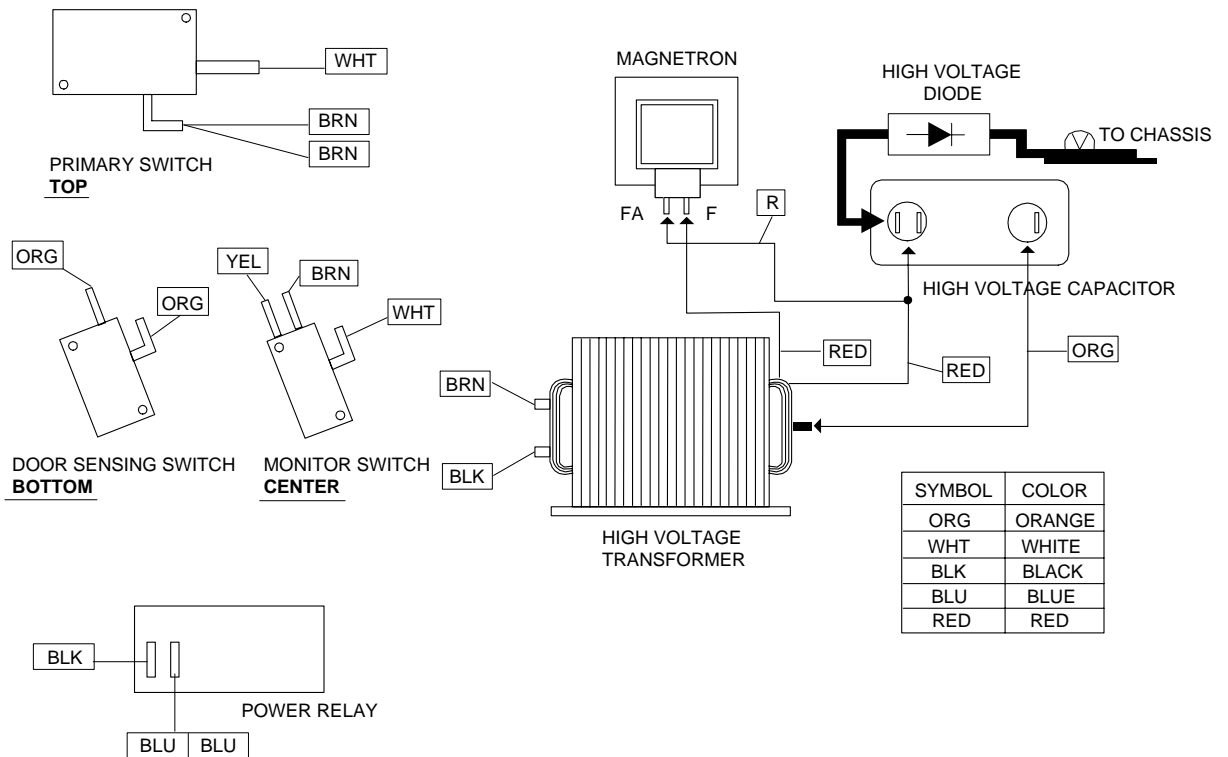
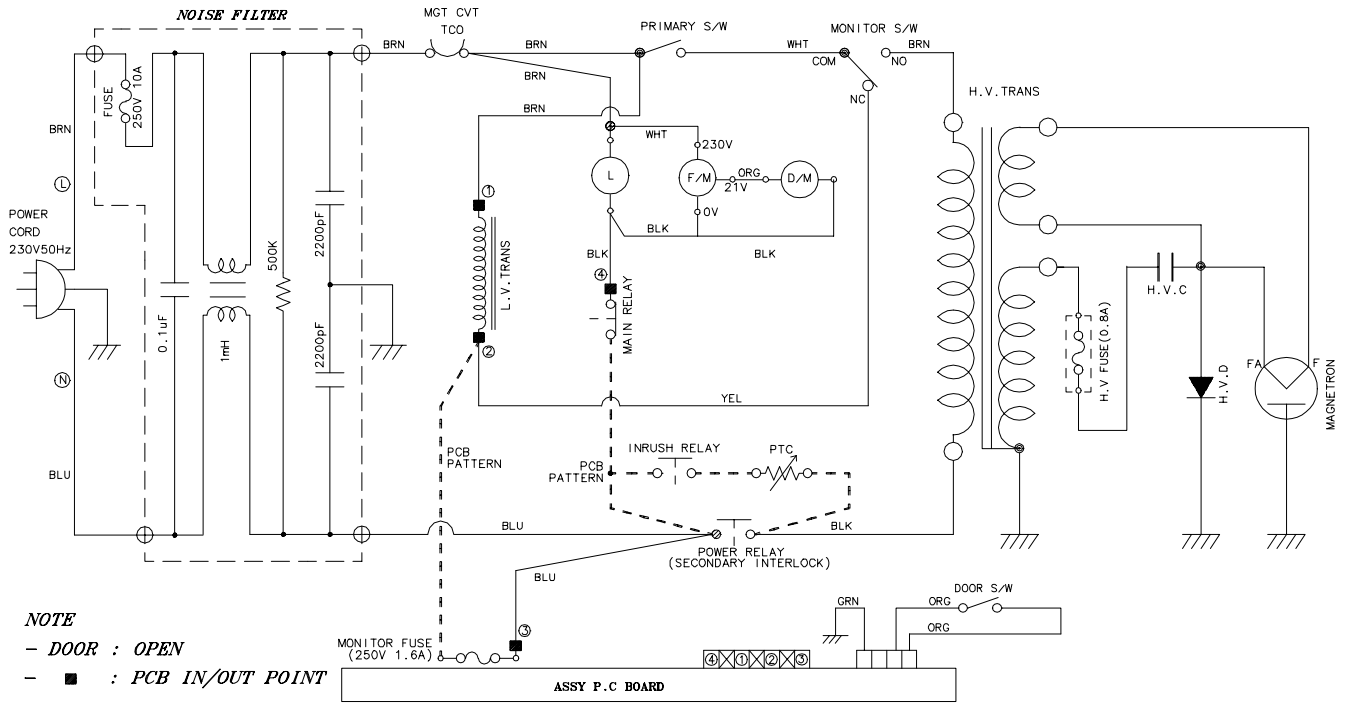

# Bonn

---

February 2002

Printed in Korea

Code No. : DE68-02529A

COMMERCIAL MICROWAVE OVEN